

AC Servo Motor & D2 Drive

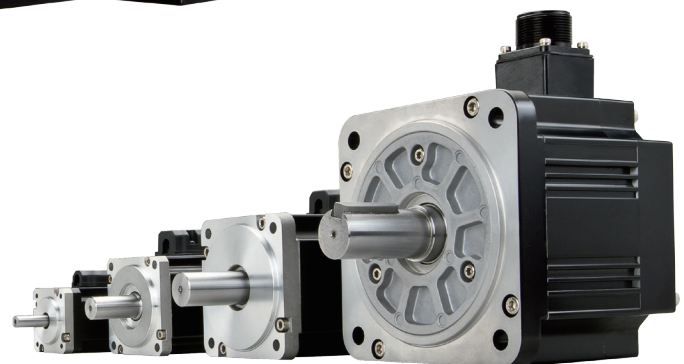

Technical Information



Linear Motor Stage

- Automated transport / AOI application / Precision / Semiconductor
- Iron-core Linear Motor
 - Coreless Linear Motor
 - Linear Shaft Motor LMT
 - Planar Servo Motor
 - Air Bearing Platform
 - X-Y Stage
 - Gantry Systems

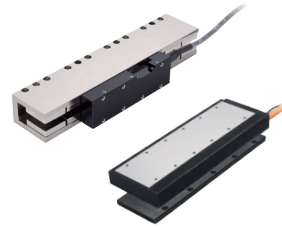

Linear Motor

- Machine tool / Touch panel industry / Semiconductor industry / Laser manufacturing machine / Glass cutting machine
- Ironcore linear motor-LMFA series, LMSA series, LMSC series
 - Ironless linear motor-LMC series, LMT series



Torque Motor (Direct Drive Motor)

- Inspection / Testing equipment / Machine tools / Robot
- Rotary Tables-TMS,TMY,TMN
 - TMRW Series
 - TMRI Series



AC Servo Motor & Drive

- Semiconductor / Packaging machine / SMT / Food industry / LCD
- Drives-D1, D1-N, D2
 - Motors-50W~2000W



Linear Actuator

- Hospital bed / Automatic window / Home care facility / Riveting / Press-fitting / Surface checks / Bending
- Servo Actuator-LAA series
 - LAM series
 - LAI series
 - LAS series
 - LAN series
 - LAC series

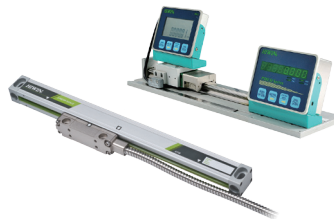

Positioning Measurement System

- Cutting machines / Traditional gantry milling machines / Programmable drilling machines
- High Resolution
 - Signal Translator
 - High-precision Enclosed
 - High Efficiency Counter



Multi Axis Robot

- Pick-and-place / Assembly / Array and packaging / Semiconductor / Electro-Optical industry / Automotive industry / Food industry
- Articulated Robot
 - Delta Robot
 - SCARA Robot
 - Wafer Robot
 - Electric Gripper
 - Integrated Electric Gripper
 - Rotary Joint



Single Axis Robot

- Precision / Semiconductor / Medical / FPD
- KK, SK
 - KS, KA
 - KU, KE, KC

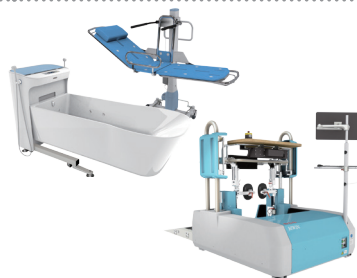

Medical Equipment

- Hospital / Rehabilitation centers / Nursing homes
- Robotic Gait Training System
 - Hygiene System
 - Robotic Endoscope Holder



Ball screw

- Precision Ground / Rolled
- Super S series
 - Super T series
 - Mini Roller
 - Ecological & Economical lubrication Module E2
 - Rotating Nut (R1)
 - Energy-Saving & Thermal-Controlling (C1)
 - Heavy Load Series (RD)
 - Ball Spline

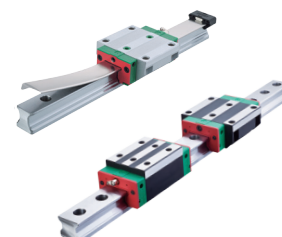

Linear Guideway

- Automation / Semiconductor / Medical
- Ball Type--HG, EG, WE, MG, CG
 - Quiet Type--QH, QE, QW, QR
 - Other--RG, E2, PG, SE, RC

With High-tech control technology, HIWIN AC Servo motors achieve a great cost-performance ratio for a complete motor drive solution.

1. Features	2
2. Safety certification	7
3. Model descriptions	8
4. Interface directions	12
5. Part numbers and options	14
6. Servo Drive	
6.1 Servo drive with standard interface	28
6.2 Wiring diagram	30
6.3 Control circuit	32
6.4 Dimensions of drive	34
6.5 Drive peripheral kits	38
7. Servo Motor	
7.1 Motor specifications and application environment	41
7.2 Low Inertia, Small Capacity	43
7.3 Middle Inertia, Small Capacity	47
7.4 Middle Inertia, Middle Capacity	51
8. Cable and connector	
8.1 Cable	53
8.2 Connector	57
9. HIWIN single axis robot and motor adaptor flange	
9.1 Introduction of motor selection relevant parameters	62
10. Servo motor selection guide	
10.1 Introduction of motor selection relevant parameters	62
10.2 General inertia calculation for various rigid objects of uniform composition	63
10.3 Equivalent inertia calculation for mechanism	64
10.4 Operating pattern / motion velocity profile	65
10.5 Motor selection sample - ballscrews mechanism	66
11. Motor / Drive Requirements List	69
12. Safety precautions	70

1. Features

Excellent performance

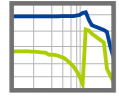

Excellently high speed response

With the help of a semiconductor high-end motion control algorithm and advanced common gain concept, a high speed response is achieved, satisfying all motion control needs.

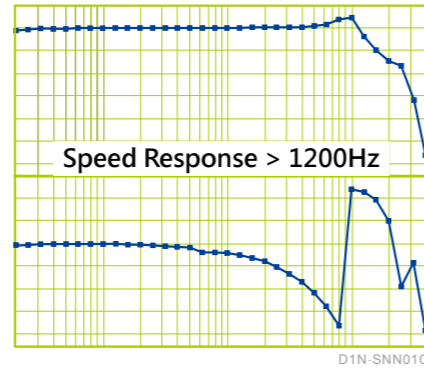

High acceleration responses

Using advanced controller design tools, and space vector current control technology, high level servo performance is achieved.

AC servo motor speed can change from -3000 to +3000 rpms in as little as 0.006 seconds.

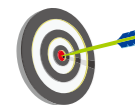
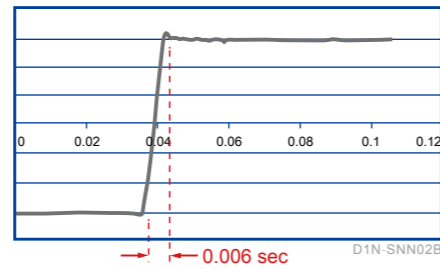

Built-in accuracy improvement feature

The D2 drive includes features to improve total positioning accuracy of the mechanical system.

The table size can be up to 5000 points. It is implemented in all control modes to optimize system behavior.

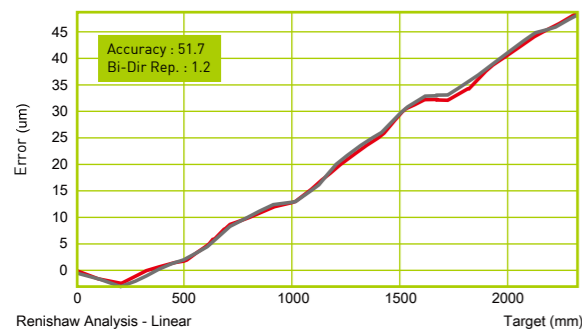

Without accuracy improvement feature

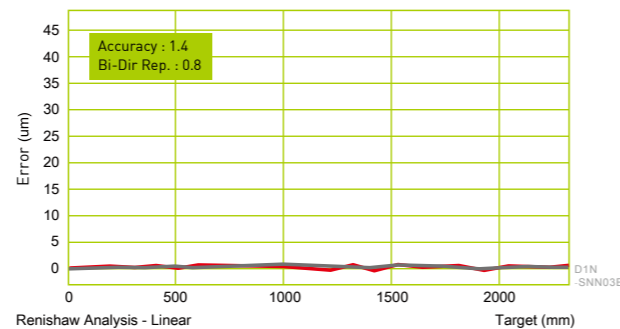

With accuracy improvement feature



Vibration Suppression Feature

The D2 drive can remove vibration frequency that occurs during movement. It reduces vibrations caused by system's structure and improves the machine's production efficiency.

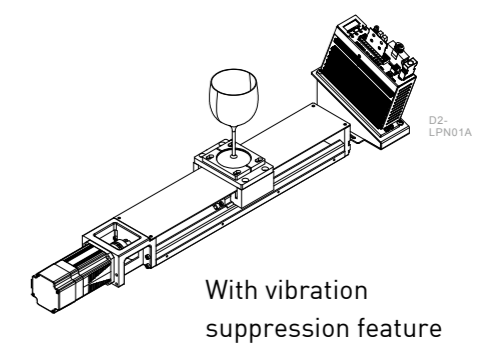
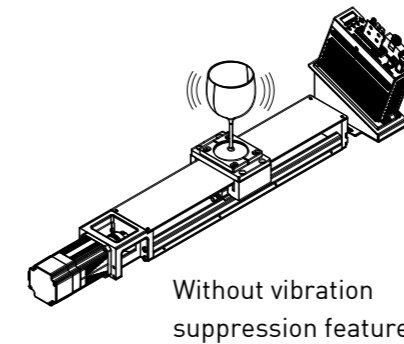

Electronic gear ratio and Encoder Emulator

The drive can help users adjust pulse resolution for the host controller, and to work with a variety of position encoders with different resolutions; it can also adjust analog position encoder output resolution to the host controller and meet the pulse receiving capability of different host controllers.

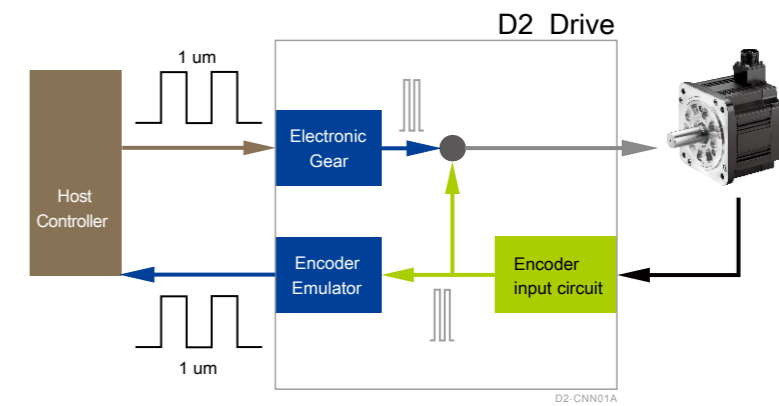

D2-CHN01A

Simple Operation

1 2 3
Three Steps

Simple setup

Auto phase center

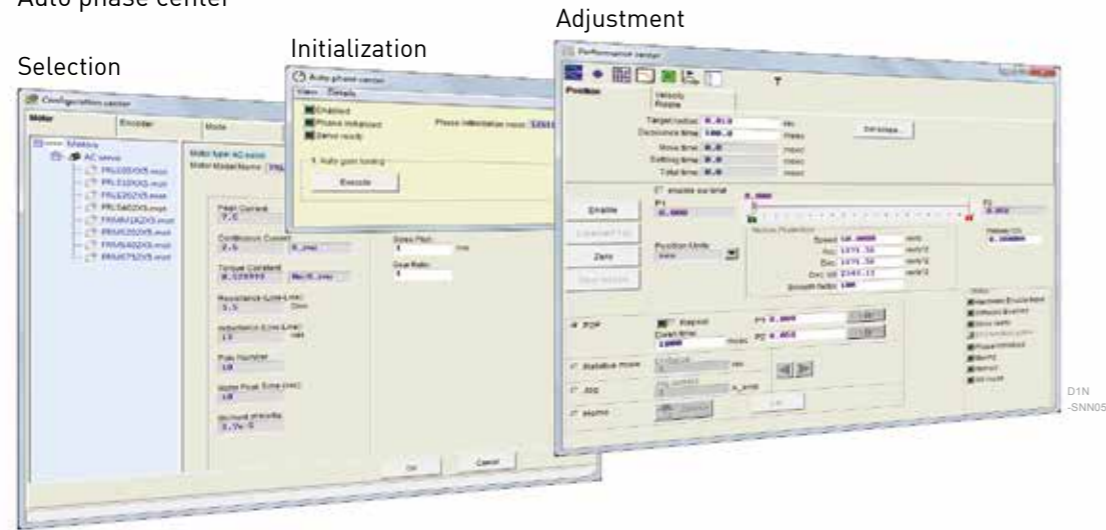

D1N-SNN05A



Easy Operation

Parameters are categorized according to features. Only necessary parameters are shown. No confusing parameter list.



D1N-SNN09B



LCD Display

No need to connect to a PC to complete all of the settings and operations. LCD display provides instant status monitoring and displays error messages. Gain and test running can be quickly set by panel keys.



D2-SNN01A

Complete tool sets

Real-time scope, accuracy enhancement function, frequency analysis tools, gain scheduling tool, analysis tool, I/O setting functions, encoder output ratio adjustment function, Z phase signal width adjustment function, PDL, ZeroTune function and filter.



Accuracy enhancement function

To improve on the positioning accuracy of motion systems, the drive amplifier is featured with an error compensation function. By taking the measurements from a laser interferometer, the positioning error table can be built inside the drive, so that high positioning accuracy is achieved.



D1N-SNN08A



Frequency analysis tools

A powerful and easy to use tool for frequency analysis is provided. You can use the frequency analysis tools to display the real response in the form of a graph. You can easily set the best gain value for the system based on the real response, even first time users can easily get started.

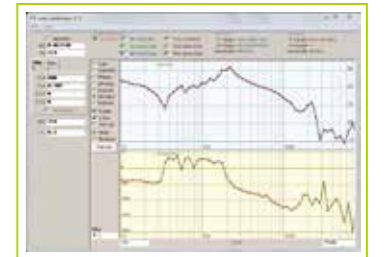

D1N-SNN10B



Advanced gain scheduling feature

After setting gains through frequency analysis tools, there is only one value to adjust: the common gain. The drive provides a gain scheduling function. You can adjust the gain according to different phases of motion, such as moving phase, settling phase, and in-position phase.



D1N-SNN09B



Variety of I / O functions

To support a number of different functions, you are free to configure the I/O pin functionality and adapt different hardware interface needs. This satisfies diverse requirements for different motion controllers with regards to their pin assignments and hardware interfaces.

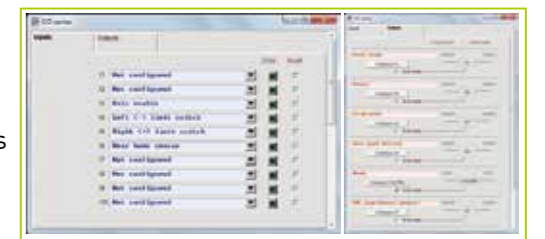

D1N-SNN11B



Analysis Tools

To solve a resonance problem, the drive offers a filter design tool for improving the control performance, a Fast Fourier Transform (FFT) and other mathematical operation tools. You can use the functions to calculate the resonant frequency of the system easily, and to make the filter design more accurate.

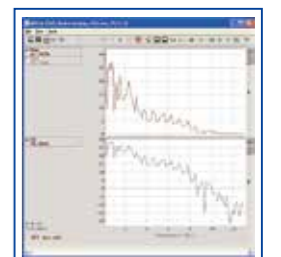

D1N-SNN12A

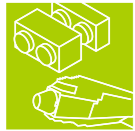

PDL (Process Description Language)

Easy-use process description language is provided.

Complex motions can be designated via PDL, such as extrusion process, point-to-point motion, fixed speed control, homing process and so on. PDL gains the advantages of flexibility and programmability. For quick learning, a number of sample programs are provided in the PDL manual.

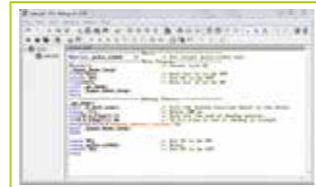

D2-SNN04A

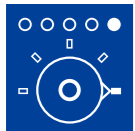

ZeroTune function

Servo loop gains can be easily set without complex procedures via ZeroTune.

Only by selecting the load level of the motor, will stable velocity response be achieved. Even a beginner who has no knowledge of servo control can easily drive a motor.



D2-SNN05A



Filter

Drive supports two sets of bi-quad filters.

According to filter parameters, the bi-quad filters can be transformed into different filter types, such as low-pass filter, notch filter, ..., etc. Through well-defined filters, stage vibration can be easily suppressed, and control accuracy can be significantly increased.

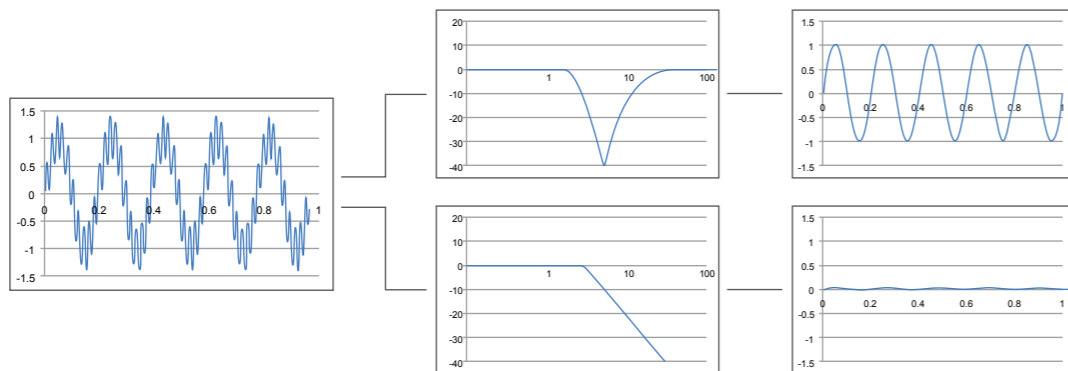

Easy integration



A complete solution with positioning module, motor and drive

In addition to providing motor and drive, a variety of linear positioning modules are provided. We provide customers with integrated services and a total solution.



High-speed network communications interface

The D2 is equipped with Industrial Ethernet communications (EtherCAT) interface, and also supports CoE (CANopen over EtherCAT) servo drive protocol. For of multi-axis control, it provides simple wiring, low cost, noise immunity, remote and distributed control needs.



Simple and robust communication interface

Equipped with Modbus communication, D-series drives support Modbus over serial lines (Modbus RTU and Modbus ASCII). On the application of automation, the motor position and velocity can be easily shown on the HMI via Modbus.

2. Safety Certification

2.1 RoHS compliant

Components and finished product all meet RoHS(Restriction of Hazardous Substances Regulation) requirements which ensure the compliance to relevant laws of quality of goods.



RoHS regulations limit six hazardous substances are: Lead (Pb), mercury (Hg), hexavalent chromium (Cr6 +), Polybrominated Biphenyls (PBB), the maximum allowable content of Polybrominated diphenyl ethers (PBDE) is 0.1% (1000ppm), Cadmium (Cd) is 0.01% (100ppm).

2.2 Comply with CE & UL regulations

		Drive	Motor
CE Directives CE	EMC Directives	EMC: EN61800-3 EN55011 EN61000-6-2 EN61000-6-4 EN61000-2-4 IEC60146-1-1 IEC61000-2-1	EN55011 EN61000-6-2 EN61000-6-4
	Low-Voltage Directives	LVDS:EN61800-5-1	EN60034-1 EN60034-5
UL Directives		UL:E348161 (D2T 100W/400W/1000W)	UL1004-1 UL1004-6

3. Model Descriptions

3.1 Servo drive

Code	1	2	2a	3	4	5	6	7	8	9	10	11	12
Example	D	2	T	-	0	4	2	3	-	S	-	B	0

Product
 HIWIN servo drive D2 = D2

Type
 17bit encoder only = T
 13bit encoder only = Blank

Rated output
 100W = 01
 400W = 04
 1000W = 10
 2000W = 20

Voltage range
 1/3 phase 110/220VAC (For A,B,C frame) = 23
 3 phase 220VAC (Only for D frame) = 32

Interface
 Standard = S
 EtherCAT(CoE) = E
 EtherCAT(mega-ulink) = F
 Standard with extension I/O modules = K
 Modbus = T

Frame size
 A frame(suggestion: 100W rated output) = A
 B frame(suggestion: 400W rated output) = B
 C frame(suggestion: 1000W rated output) = C
 D frame(suggestion: 2000W rated output) = D

Encoder type
 13bit less-wire incremental encoder = 0
 17bit serial incremental encoder(HIWIN17) = 4
 Dual Loop (Full closed loop) and 17bit serial absolute encoder = 5

Model	Interface	Standard	EtherCAT(CoE)	EtherCAT(mega-ulink)	Standard with extension I/O modules	Modbus
D2(frame A-C)		0	0	0	X	0
D2T(frame A-C)		0	0	0	△	X
D2T(frame D)		0	0	0	△	△

0: Available X:Unavailable △:Please contact with Sales Representative.

Note Single and three phase AC voltage drive only support rated output which is lower or equal to 1000W.

3.2 Servo motor

Code	1	2	3	4	5	6	7	8	9	10	11	12
Example	F	R	L	S	4	0	2	0	6	0	6	A

Product
 HIWIN AC servo motor series = FR

Type
 Low inertia, small capacity(50W~400W) = LS
 Medium inertia, small capacity(50W/100W/400W/750W) = MS
 Medium inertia, medium capacity(1000W/2000W) = MM

Output Power
 50W = 05
 100W = 10
 200W = 20
 400W(Low inertia) = 40
 400W(Medium inertia) = 4B
 750W = 75
 1000W = 1K
 2000W = 2K

Drive input voltage
 220V = 2

Holding brake options
 Without holding brake = 0
 With holding brake = B

Encoder type
 13bit incremental encoder⁽¹⁾ = 5
 17bit absolute encoder = 4
 HIWIN 17 incremental encoder = 6

Frame size
 40mm(MS 50W/100W) = 04
 42mm(LS 50W/100W) = A4
 60 mm(200W/400W) = 06
 80 mm(750W) = 08
 130 mm(1000W/2000W) = 13

Motor shaft
 Round shaft / without oil seal = A
 Round shaft / with oil seal⁽²⁾ = B
 With key and center tap / without oil seal = C
 With key and center tap / with oil seal⁽²⁾ = D

! (1) 13bit only supports FRLS05/10/20/40,FRMS75,FRMM1K
 (2) FRLS 05/10 For the motor with oil seal,please contact Sales Representative

3.3 Motor cable

Code	1	2	3	4	5	6	7	8	9	10	11	12
Example	H	V	P	S	0	4	A	A	0	5	M	B

Type
 HIWIN motor cable = HVP

Capacity
 Small capacity (50W~750W) = S
 Medium capacity (1000W/2000W) = M

Number of pin
 Motor cable without holding brake = 04
 Motor cable with holding brake = 06

Motor side connector
 AMP connector (50W~750W) = A
 Straight waterproof connector (1000W/2000W) = B
 L-type waterproof connector (1000W/2000W) = C

Drive side connector
 Open cable ends (50W~1000W) = A
 R-type terminals (2000W) = B

Cable length
 3M = 03M
 5M = 05M
 7M = 07M
 10M = 10M

Cable type
 Highly flexible = B

3.4 Encoder cable

Code	1	2	3	4	5	6	7	8	9	10	11	12
Example	H	V	E	1	7	I	A	B	0	5	M	B

Type
 HIWIN encoder cable = HVE

Encoder Type
 13bit incremental encoder = 13I
 HIWIN 17 incremental encoder = 17I
 17bit absolute encoder = 17A

Encoder connector
 AMP connector (50W~750W) = A
 Straight waterproof connector (1000W/2000W) = B
 L-type waterproof connector (1000W/2000W) = C

Drive side connector
 SCR connector = B

Cable length
 3M = 03M
 5M = 05M
 7M = 07M
 10M = 10M

Cable type
 Highly flexible = B

4. Interface Directions

4.1 Frame A-C

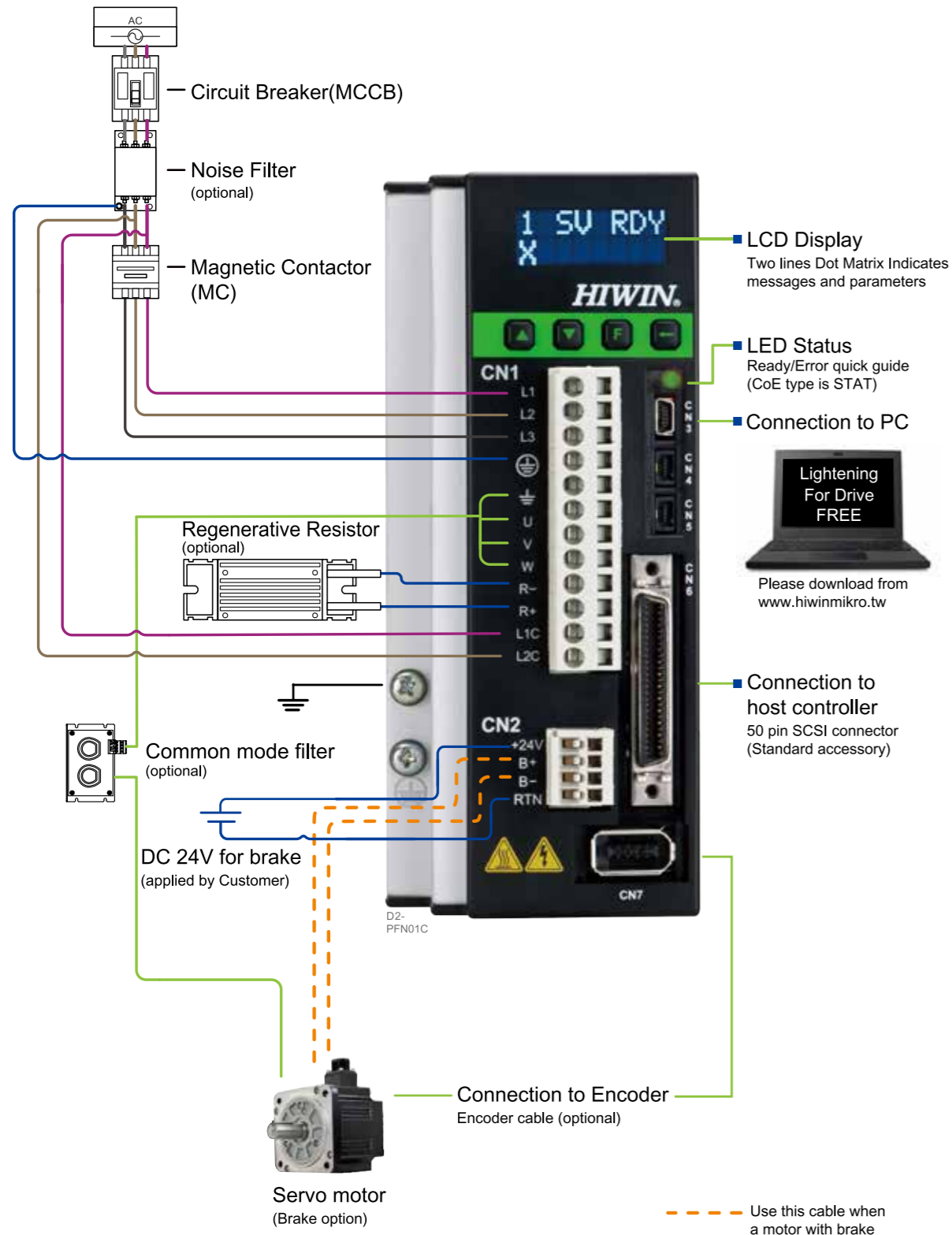

4.2 Frame D

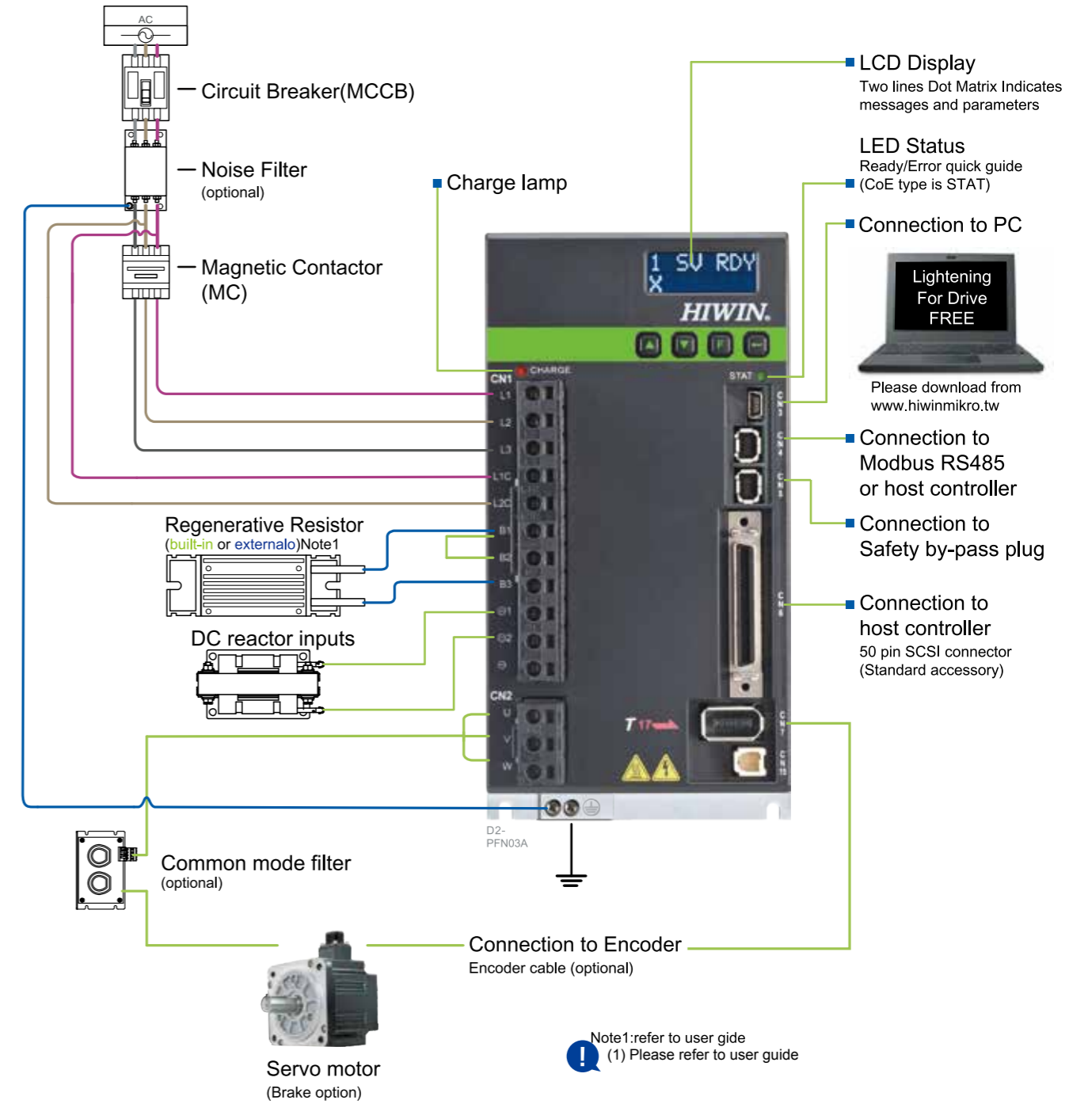

5. Part numbers and options

Name	Motor cable		Encoder cable	Other accessories
50W 750W	without brake		HVPS04AA	HVE13IAB HVE17IAB HVE17AAB
	with brake		HVPS06AA	
1000W	without brake	Straight type	HVPM04BA	HVE13IBB(Straight type) HVE17IBB(Straight type) HVE17ABB(Straight type) HVE13ICB(L-type) HVE17ICB(L-type) HVE17ACB(L-type)
		L-type	HVPM04CA	
	with brake	Straight type	HVPM06BA	
		L-type	HVPM06CA	
2000W	without brake	Straight type	HVPM04BB	HVE17IBB(Straight type) HVE17ABB(Straight type) HVE17ICB(L-type) HVE17ACB(L-type)
		L-type	HVPM04CB	
	with brake	Straight type	HVPM06BB	
		L-type	HVPM06CB	

! Straight type : straight waterproof connector
L-type : waterproof connector



5.1 AC50W~AC750W – 13bit incremental encoder

Motor				Drive			Optional parts							
Motor Series	Power supply	Output (W)	Part No. (Note 1)	Part No. (Standard interface)	Frame	Power capacity (Rated load)	Motor cable(Note 2)		Encoder cable	D2 drive accessories				
							without brake	with brake	13bit incremental (Note 2)	Control Signal Cable	Single phase EMC Pack (Note 3)	Three phase EMC Pack (Note 3)	External Regenerative Resistor	
Low Inertia	FRLS	single phase/ three phase 220V	50	FRLS05205A4△	D2-0123-S-A0	Frame A	Approx. 0.4kVA	HVPS04AA□□□B	HVPS06AA□□□B	HVE13IAB□□□B	LMACK02D	D2-EMC1	D2-EMC2	N/A
				FRLS052B5A4△										
			100	FRLS10205A4△										
				FRLS102B5A4△										
			200	FRLS2020506△	D2-0423-S-B0	Frame B	Approx. 0.9kVA							
				FRLS202B506△										
400	FRLS4020506△													
	FRLS402B506△													
Middle inertia	FRMS	750	FRMS7520508△	D2-1023-S-C0	Frame C	Approx. 1.8kVA					D2-EMC3		RG2	
			FRMS752B508△											

Note1 △ : Shaft End & Oil Seal Specification (Please refer to P.9)

Note3 EMC pack model (please refer to P.38)

Note2 Selection of cable / 50W~750W

■ Motor cable / without brake

HVPS04AA □□□ B

Cable length

- 3M.....=03M
- 5M.....=05M
- 7M.....=07M
- 10M.....=10M

Cable type

Highly flexible = B

■ Motor cable and brake cable / with brake

HVPS06AA □□□ B

Cable length

- 3M.....=03M
- 5M.....=05M
- 7M.....=07M
- 10M.....=10M

Cable type

Highly flexible = B

■ Encoder cable / 13bit incremental

HVE13IAB □□□ B

Cable length

- 3M.....=03M
- 5M.....=05M
- 7M.....=07M
- 10M.....=10M

Cable type

Highly flexible = B

! For more information about cables, please refer to P.52-P.58

5.2 AC1000W – 13bit incremental encoder

Motor				Drive		Power capacity (Rated load)	Optional parts							
Motor Series	Power supply	Output (W)	Part No. (Note 1)	Part No. (Standard interface)	Frame		Motor cable(Note 2)		Encoder cable	D2 drive accessories				
							without brake	with brake	13bit incremental (Note 2)	Control Signal Cable	Single phase EMC Pack (Note 3)	Three phase EMC Pack (Note 3)	External Regenerative Resistor	
Middle inertia	FRMM	single phase/ three phase 220V	1000	FRMM1K20513Δ FRMM1K2B513Δ	D2-1023-S-C0	Frame C	Approx. 1.8kVA	HVPM04□A□□□B	HVPM06□A□□□B	HVE13I□B□□□B	LMACK02D	D2-EMC3	D2-EMC2	RG2

Note1 Δ : Shaft End & Oil Seal Specification (Please refer to P.9)

Note3 EMC pack model (please refer to P.38)

Note2 Selection of cable / 1000W

Motor cable / without brake

HVPM04□A□□□ B

Motor side connector
Straight Type=B
L-Shaped Type=C

Cable length
3M.....=03M
5M.....=05M
7M.....=07M
10M.....=10M

Cable type
Highly flexible= B

Motor cable and brake cable / with brake

HVPM06□A□□□ B

Motor side connector
Straight Type=B
L-Shaped Type=C

Cable length
3M.....=03M
5M.....=05M
7M.....=07M
10M.....=10M

Cable type
Highly flexible= B

Encoder cable / 13bit incremental

HVE13I□B□□□ B

Motor side connector
Straight Type=B
L-Shaped Type=C

Cable length
3M.....=03M
5M.....=05M
7M.....=07M
10M.....=10M

Cable type
Highly flexible= B

! For more information about cables, please refer to P.52-P.58

Note5 Medium capacity motor brake power cables are packaged.
Item number HVPM06:
Contains one motor cable and brake cable labeled with HVPM04 and HVPM02.

5.3 AC50W~AC750W – 17bit incremental encoder

Motor				Drive			Optional parts								
Motor Series	Power supply	Output (W)	Part No. (Note 1)	Part No. (Standard interface)	Frame	Power capacity (Rated load)	Motor cable(Note 2)		Encoder cable	D2 drive accessories					
							without brake	with brake	17bit incremental (Note 2)	Control Signal Cable	Single phase EMC Pack (Note 3)	Three phase EMC Pack (Note 3)	External Regenerative Resistor		
Low Inertia	FRLS	single phase/ three phase 220V	50	FRLS05206A4Δ	D2T-0123-S-A4	Frame A	Approx. 0.4kVA	HVPS04AA□□□B	HVPS06AA□□□B	HVE17IAB□□□B	LMACK02D	D2-EMC1	D2-EMC2	RG1	N/A
				FRLS052B6A4Δ											
			100	FRLS10206A4Δ											
				FRLS102B6A4Δ											
			200	FRLS2020606Δ	D2T-0423-S-B4	Frame B									
				FRLS202B606Δ											
400	FRLS4020606Δ														
	FRLS402B606Δ														
Middle inertia	FRMS	single phase/ three phase 220V	50	FRMS0520604Δ	D2T-0123-S-A4	Frame A	Approx. 0.4KVA	HVPS04AA□□□B	HVPS06AA□□□B	HVE17IAB□□□B	LMACK02D	D2-EMC3	D2-EMC2	RG2	
				FRMS052B604Δ											
			100	FRMS1020604Δ											
				FRMS102B604Δ											
			400	FRMS4B20606Δ	D2T-0423-S-B4	Frame B									
				FRMS4B2B606Δ											
750	FRMS7520608Δ	D2T-1023-S-C4	Frame C												
	FRMS752B608Δ														

Note1 Δ : Shaft End & Oil Seal Specification (Please refer to P.9)

Note3 EMC pack model (please refer to P.38)

Note2 Selection of cable / 50W~750W

■ Motor cable / without brake

HVPS04AA □□□ B

Cable length

- 3M.....=03M
- 5M.....=05M
- 7M.....=07M
- 10M.....=10M

Cable type

Highly flexible = B

■ Motor cable and brake cable / with brake

HVPS06AA □□□ B

Cable length

- 3M.....=03M
- 5M.....=05M
- 7M.....=07M
- 10M.....=10M

Cable type

Highly flexible = B

■ Encoder cable / 17bit incremental

HVE17IAB □□□ B

Cable length

- 3M.....=03M
- 5M.....=05M
- 7M.....=07M
- 10M.....=10M

Cable type

Highly flexible = B

! For more information about cables, please refer to P.52-P.58

5.4 AC1000W/AC2000W – 17bit incremental encoder

Motor				Drive			Optional parts							
Motor Series	Power supply	Output (W)	Part No. (Note 1)	Part No. (Standard interface)	Frame	Power capacity (Rated load)	Motor cable(Note 2)		Encoder cable	D2 drive accessories				
							without brake	with brake	17bit incremental (Note 2)	Control Signal Cable	Single phase EMC Pack (Note 3)	Three phase EMC Pack (Note 3)	External Regenerative Resistor	
Middle inertia	FRMM	single phase/ three phase 220V	1000	FRMM1K20613△ FRMM1K2B613△	D2T-1023-S-C4	Frame C	Approx. 1.8kVA	HVPM04□A□□□B	HVPM06□A□□□B	HVE17I□B□□□B	LMACK02D	D2-EMC3	D2-EMC2	RG2
		three phase 220V	2000	FRMM2K20613△ FRMM2K2B613△	D2T-2032-S-D4	Frame D	Approx. 3.5kVA	HVPM04□B□□□B	HVPM06□B□□□B					

Note1 △ : Shaft End & Oil Seal Specification (Please refer to P.9)

Note3 EMC pack model (please refer to P.38)

Note2 Selection of cable / 1000W, 2000W

■ Motor cable / without brake

HVPM04□ A □□□ B

Motor side connector
Straight Type=B
L-Shaped Type=C

Drive side connector
Open cable ends =A
R-type terminals =B

Cable length
3M.....=03M
5M.....=05M
7M.....=07M
10M.....=10M

Cable type
Highly flexible = B

■ Motor cable and brake cable / with brake

HVPM06□ A □□□ B

Motor side connector
Straight Type=B
L-Shaped Type=C

Drive side connector
Open cable ends =A
R-type terminals =B

Cable length
3M.....=03M
5M.....=05M
7M.....=07M
10M.....=10M

Cable type
Highly flexible = B

■ Encoder cable / 17bit incremental

HVE17I□B□□□ B

Motor side connector
Straight Type=B
L-Shaped Type=C

Cable length
3M.....=03M
5M.....=05M
7M.....=07M
10M.....=10M

Cable type
Highly flexible= B

! For more information about cables, please refer to P.52-P.58

Note5 Medium capacity motor brake power cables are packaged.
Item number HVPM06:
Contains one motor cable and brake cable labeled with HVPM04 and HVPM02.

5.5 AC50W~AC750W – 17bit absolute encoder

Motor				Drive			Optional parts								
Motor Series	Power supply	Output (W)	Part No. (Note 1)	Part No. (Standard interface)	Frame	Power capacity (Rated load)	Motor cable(Note 2)		Encoder cable	D2 drive accessories					
							without brake	with brake	17bit absolute (Note 2)	Control Signal Cable	Single phase EMC Pack (Note 3)	Three phase EMC Pack (Note 3)	External Regenerative Resistor		
Low Inertia	FRLS	single phase/ three phase 220V	50	FRLS05204A4Δ	D2T-0123-S-A5	Frame A	Approx. 0.4KVA	HVPS04AA□□□B	HVPS06AA□□□B	HVE17AAB□□□B	LMACK02D	D2-EMC1	D2-EMC2	RG1	N/A
				FRLS052B4A4Δ											
			100	FRLS10204A4Δ	D2T-0423-S-B5	Frame B	Approx. 0.9kVA								
				FRLS102B4A4Δ											
			200	FRLS2020406Δ	D2T-0423-S-B5	Frame B	Approx. 0.9kVA								
				FRLS202B406Δ											
400	FRLS4020406Δ	D2T-0423-S-B5	Frame B	Approx. 0.9kVA											
	FRLS402B406Δ														
Middle inertia	FRMS	single phase/ three phase 220V	50	FRMS0520404Δ	D2T-0123-S-A5	Frame A	Approx. 0.4KVA	HVPS04AA□□□B	HVPS06AA□□□B	HVE17AAB□□□B	LMACK02D	D2-EMC3	D2-EMC2	RG2	N/A
				FRMS052B404Δ											
			100	FRMS1020404Δ	D2T-0423-S-B5	Frame B	Approx. 0.9KVA								
				FRMS102B404Δ											
			400	FRMS4B20406Δ	D2T-0423-S-B5	Frame B	Approx. 0.9KVA								
				FRMS4B2B406Δ											
750	FRMS7520408Δ	D2T-1023-S-C5	Frame C	Approx. 1.8KVA											
	FRMS752B408Δ														

Note1 Δ : Shaft End & Oil Seal Specification (Please refer to P.9)

Note3 EMC pack model (please refer to P.38)

Note2 Selection of cable / 50W~750W

■ Motor cable / without brake

HVPS04AA □□□ B

Cable length

- 3M.....=03M
- 5M.....=05M
- 7M.....=07M
- 10M.....=10M

Cable type

Highly flexible = B

■ Motor cable and brake cable / with brake

HVPS06AA □□□ B

Cable length

- 3M.....=03M
- 5M.....=05M
- 7M.....=07M
- 10M.....=10M

Cable type

Highly flexible = B

■ Encoder cable / 17bit absolute

HVE17AAB □□□ B

Cable length

- 3M.....=03M
- 5M.....=05M
- 7M.....=07M
- 10M.....=10M

Cable type

Highly flexible = B

! For more information about cables, please refer to P.52-P.58

5.6 AC1000W/AC2000W – 17bit absolute encoder

Motor				Drive		Power capacity (Rated load)	Optional parts							
Motor Series	Power supply	Output (W)	Part No. (Note 1)	Part No. (Standard interface)	Frame		Motor cable(Note 2)		Encoder cable	D2 drive accessories				
							without brake	with brake	17bit absolute (Note 2)	Control Signal Cable	Single phase EMC Pack (Note 3)	Three phase EMC Pack (Note 3)	External Regenerative Resistor	
Middle inertia	FRMM	single phase/ three phase 220V	1000	FRMM1K20413△	D2T-1023-S-C5	Frame C	Approx. 1.8kVA	HVPM04□A□□□B	HVPM06□A□□□B	HVE17A□B□□□B	LMACK02D	D2-EMC3	D2-EMC2	RG2
				FRMM1K2B413△										
	2000	FRMM2K20413△	D2T-2032-S-D5	Frame D	Approx. 3.5kVA	HVPM04□B□□□B	HVPM06□B□□□B							
						FRMM2K2B413△								

Note1 △ : Shaft End & Oil Seal Specification (Please refer to P.9)

Note3 EMC pack model (please refer to P.38)

Note2 Selection of cable / 1000W, 2000W

■ Motor cable / without brake

HVPM04□ A □□□ B

Motor side connector

Straight Type=B

L-Shaped Type=C

Drive side connector

Open cable ends =A

R-type terminals =B

Cable length

3M.....=03M

5M.....=05M

7M.....=07M

10M.....=10M

Cable type

Highly flexible = B

■ Motor cable and brake cable / with brake

HVPM06□ A □□□ B

Motor side connector

Straight Type=B

L-Shaped Type=C

Drive side connector

Open cable ends =A

R-type terminals =B

Cable length

3M.....=03M

5M.....=05M

7M.....=07M

10M.....=10M

Cable type

Highly flexible = B

■ Encoder cable / 17bit absolute

HVE17A□B□□□ B

Motor side connector

Straight Type=B

L-Shaped Type=C

Cable length

3M.....=03M

5M.....=05M

7M.....=07M

10M.....=10M

Cable type

Highly flexible = B

! For more information about cables, please refer to P.52-P.58

Note5 Medium capacity motor brake power cables are packaged.
Item number HVPM06:
Contains one motor cable and brake cable labeled with HVPM04 and HVPM02.

6. Servo Drive

6.1 Servo drive with standard interface

Specifications

Input power	220V	Main power	Frame A~C	Single/three-phase, 200 to 240V 50/60Hz
			Frame D	Three-phase, 200-240 Vac 50/60Hz
		Control power	Frame A~D	Single phase, 200 to 240V 50/60Hz
Environment	Temperature		Operation Temperature: 0°C~45°C (If temperature is higher than 45°C, ventilation is needed) Storage Temperature: -20°C~65°C	
	Humidity		0 to 90%RH (no frost)	
	Altitude		Under 1000 Meters	
	Vibration		1G (10 to 500Hz)	
Control method			IGBT PWM space vector control	
Encoder feedback			13bit incremental 17bit incremental Dual loop (Full closed loop) and 17bit absolute	
I/O signal connector	Control signal	Input	General purpose 9 inputs (D2T:10)	
		Output	General purpose 4 outputs (D2T:5)	
	Analog signal	Input	1 input (12bit A/D)	
		Output	2 outputs (Analog monitor-under construction)	
	Pulse signal	Input	2 inputs (Low speed channel, High speed channel)	
		Output	4 outputs (Line drive: 3output, open collector: 1 output)	
Brake connector	Control signal	Output	Direct brake connection. (No need of extra relay for brake) Also programmable for general purpose output	
Communication function		USB	Connection with PC, 115200bps	
Front panel		Dot matrix 2*8 characters LCD with 4 buttons LED(green, red)		
Regenerative function		Frame A-C	Need external connection, no internal regenerative resistor	
		Frame D	Built in or external regenerative resistor (option), 13Ω±5%, continue power 120W, Peak power 600W	
Control mode		Switching among the following modes is possible (1)Position control (2)Velocity control (3)Torque control (4)Position/Velocity control (5)Position/Torque control (6)Velocity/Torque control		
Dynamic brake		Frame A-C	N/A	
		Frame D	Built in line resistance: 2.6 Ω ± 5%, continuous power: 120 W, peak power: 600 W	

Functions

Position control	Control input		(1)Axis enable; (2)Left and right limit switch; (3)Home OK, start err. map; (4)Reset amplifier; (5)Near home sensor; (6)Clear error; (7)Switch to secondary CG and vpg; (8)Inhibit pulse command; (9)Switch HI/LO pulse input; (10)Abort motion; (11)Switch to secondary mode; (12)Start homing; (13)Electronic gear select (DIV1/DIV2)
	Control output		(1)Brake; (2)Servo ready; (3)Axis disable; (4)In-position; (5)Moving; (6)Homed; (7)Emulated index; (8)Zero speed detected; (9)Errors
	Pulse input	Max. command pulse frequency	Dedicated interface for Photo-coupler(single end input): 500kpps Dedicated interface for line drive(differential input): 4Mpps(16M cnt/s with AqB)
		Input pulse signal format	(1)Pulse and Direction (2)Pulse Up/Pulse Down (3)Quadrature(AqB)
		Electronic gear (Division/Multiplication of command pulse)	Gear ratio : pulses/counts pulses : 1~2, 147, 483, 647 counts : 1~2, 147, 483, 647
Smoothing filter		Smooth factor : 1~500 (0: no smoothing filter)	
Vibration suppression filter(VSF)		VSF can remove the vibration frequency that occurs during movement. It can reduce the vibration caused by the system's structure and improve the machine's productivity.	
Velocity control	Control input		(1)Axis enable; (2)Left and right limit switch; (3)Home OK, start err. map; (4)Reset amplifier; (5)Near home sensor; (6)Clear error; (7)Invert V command; (8)Switch to secondary CG and vpg; (9)Zero speed clamp; (10)Abort motion; (11)Switch to secondary mode
	Control output		(1)Brake; (2)Servo ready; (3)Axis disable; (4)In-position; (5)Moving; (6)Homed; (7)Emulated index; (8)Zero speed detected; (9)Errors
	PWM input	Velocity command input	Speed command input can be provided by means of duty cycle of PWM input. Parameter are used for scale setting and command polarity.
	Analog Input	Velocity command input	Speed instruction can be set with analog voltage method, parameters can set ratio and direction +/-10V
	Zero speed clamp		Zero speed clamp input is possible.
Torque control	Control input		(1)Axis enable; (2)Left and right limit switch; (3)Home OK, start err. map; (4)Reset amplifier; (5)Near home sensor; (6)Clear error; (7)Invert V command; (8)Switch to secondary CG and vpg; (9)Switch to secondary mode
	Control output		(1)Brake; (2)Servo ready; (3)Axis disable; (4)In-position; (5)Moving; (6)Homed; (7)Emulated index; (8)Zero speed detected; (9)Errors
	PWM input	Torque command input	Torque command input can be provided by means of duty cycle of PWM input. Parameter are used for scale setting and command polarity.
	Analog Input	Torque command input	Torque command input can be provided by means of analog voltage. Parameter are used for scale setting and command polarity.
	Speed limit function		Speed limit value with parameter is possible
ZeroTune		ZeroTune can find the proper gains by clicking one button on LCD when the motor is disable.	
Emulated encoder feedback output		Set up of any value is possible (frequency up to 18M cnt/s, only frame D drive up to 9M cnt/s)	
Common	Protective function		(1)Motor short detection; (2)Over voltage; (3)Position error too big; (4)Encoder error; (5)Soft thermal threshold reached; (6)Motor maybe disconnect; (7)Amplifier over temperature; (8)Under voltage; (9)5V for encoder card fail; (10)Phase init. error; (11)Serial encoder communication error; (12)Hall sensor error; (13)Current control error; (14)Hybrid deviation too big; (15)HFLT inconsistent error; (16)Incompatible motor model for drive; (17)DC bus voltage abnormal; (18)EtherCAT interface disconnected
	Error log		Errors and warnings are saved in non-volatile memory
	Error Mapping		Method: Established compensation table to compensate encoder error by linear interpolation Samples: Maximum 5,000 point Storage: Flash ROM, Disc file Unit: count Activation: Activated internally by home complete, or activated externally by input signal
	Others		Friction compensation, Backlash compensation

6.2 Wiring diagram

Single-phase

Recommended models: FN2090-6-06 filter	
Maximum continuous operating voltage	250VAC, 50/60Hz
Operating Frequency	DC to 400Hz
Rated Current	6A@40°C
Surge pulse protection	2kV, IEC 61000-4-5

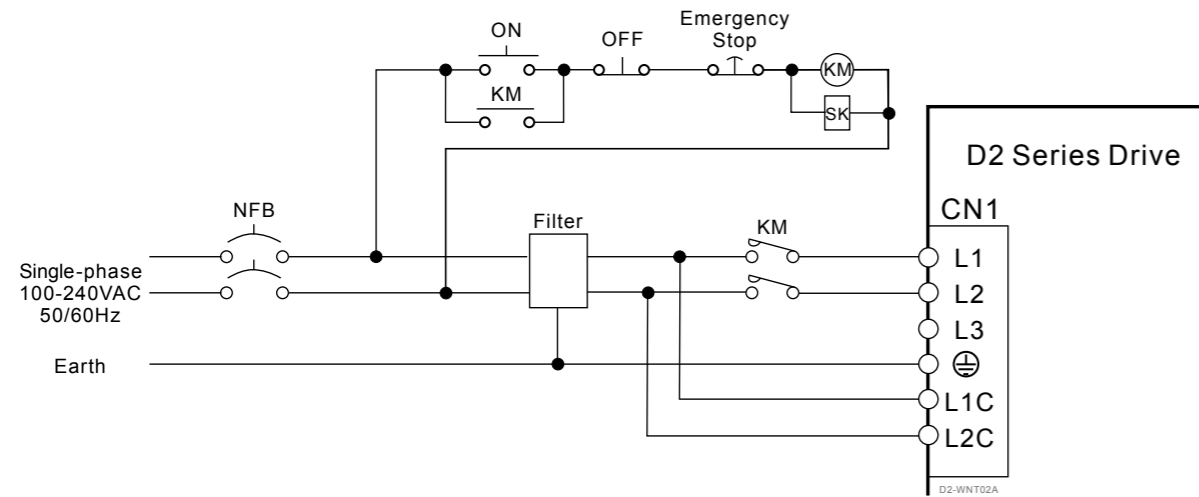

Three-phase

Recommended models: FN3025L-20-71 filter	
Maximum continuous operating voltage	3x520/300 VAC
Operating Frequency	DC to 400Hz
Rated Current	20A@50°C

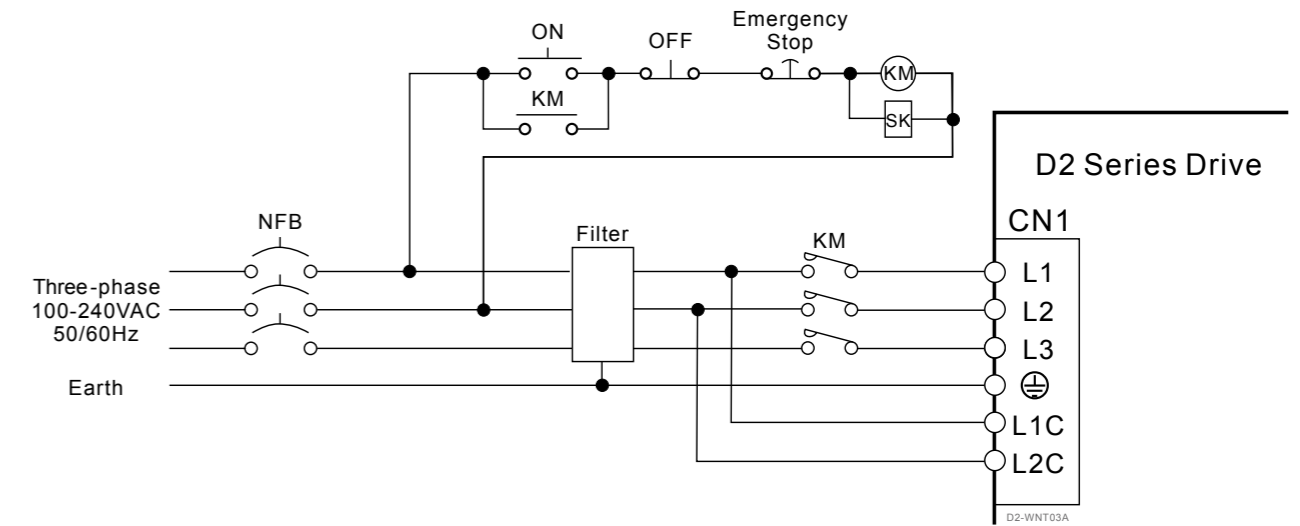

6.3 Control circuit

■ Wiring Example of Position Control Mode

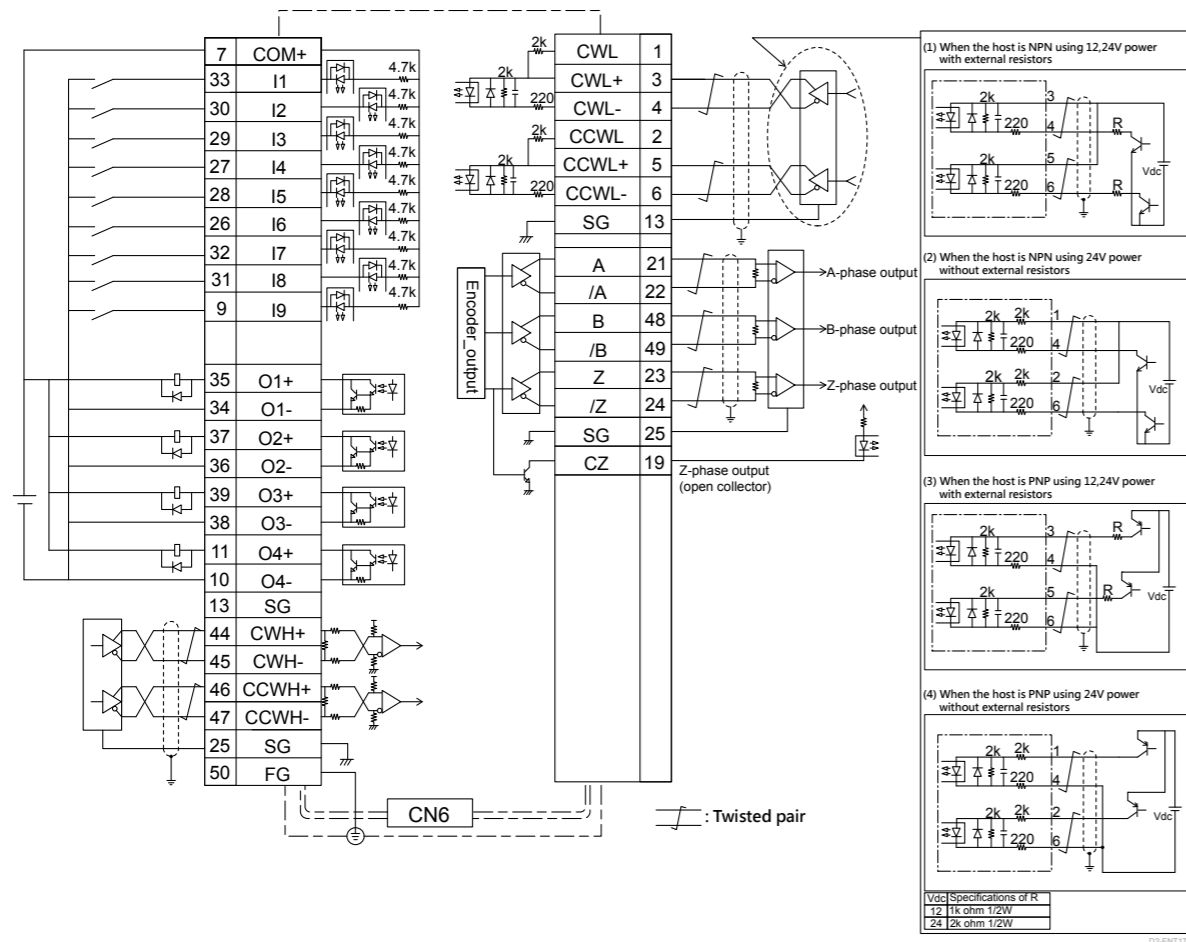

■ Wiring Example of Velocity/Torque Control Mode

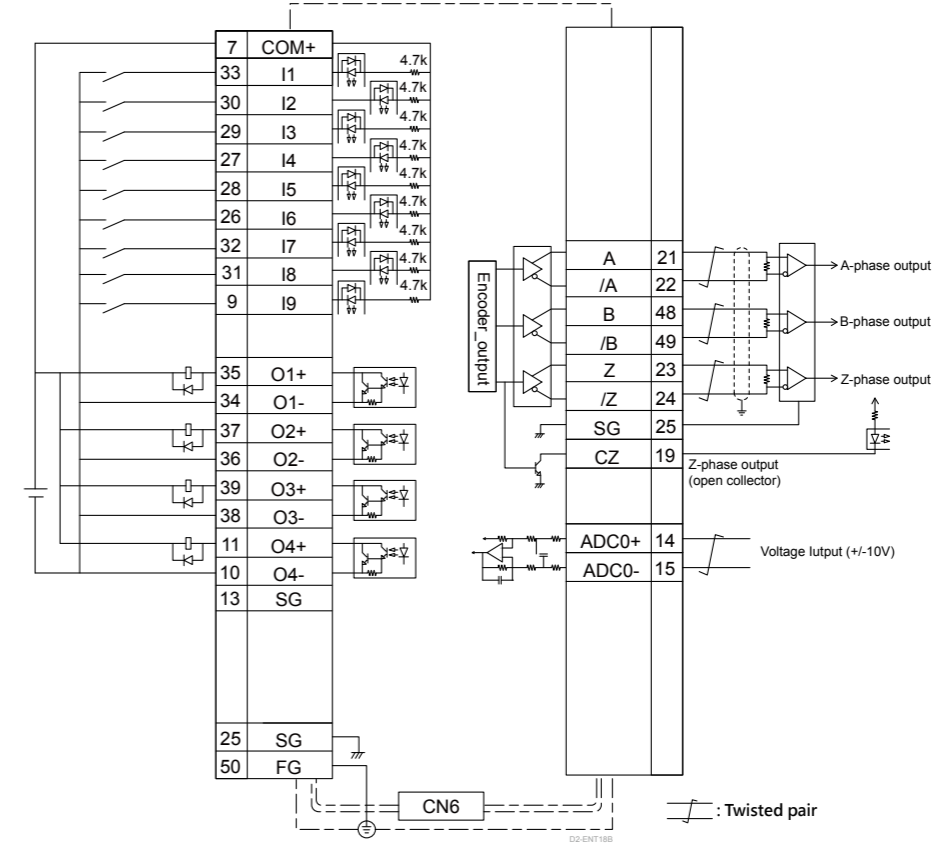

■ Additional I/O pins (Only for D2T drive)

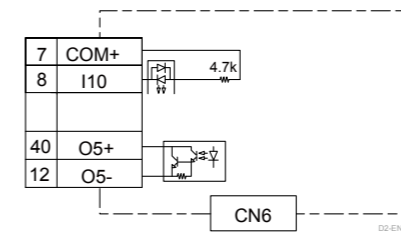

6.4 Dimensions of drive

■ Frame A (D2x-01xx-S(T)-Ax)

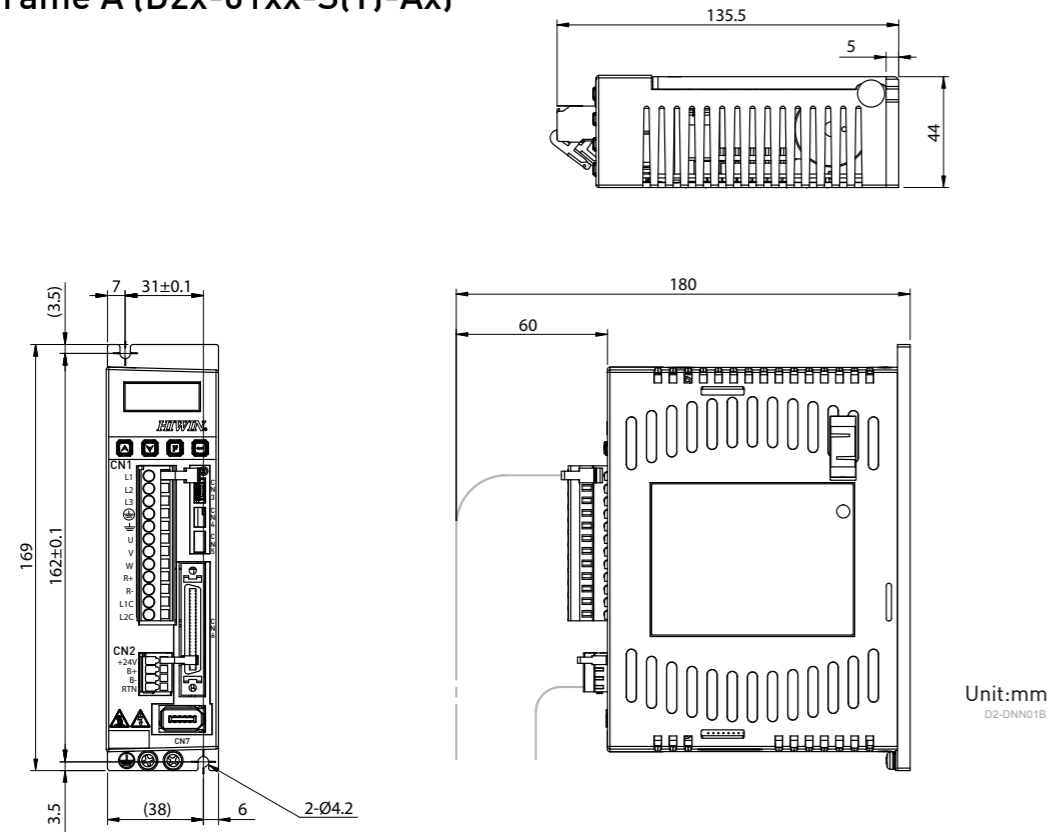

■ Frame C (D2x-10xx-S(T)-Cx)

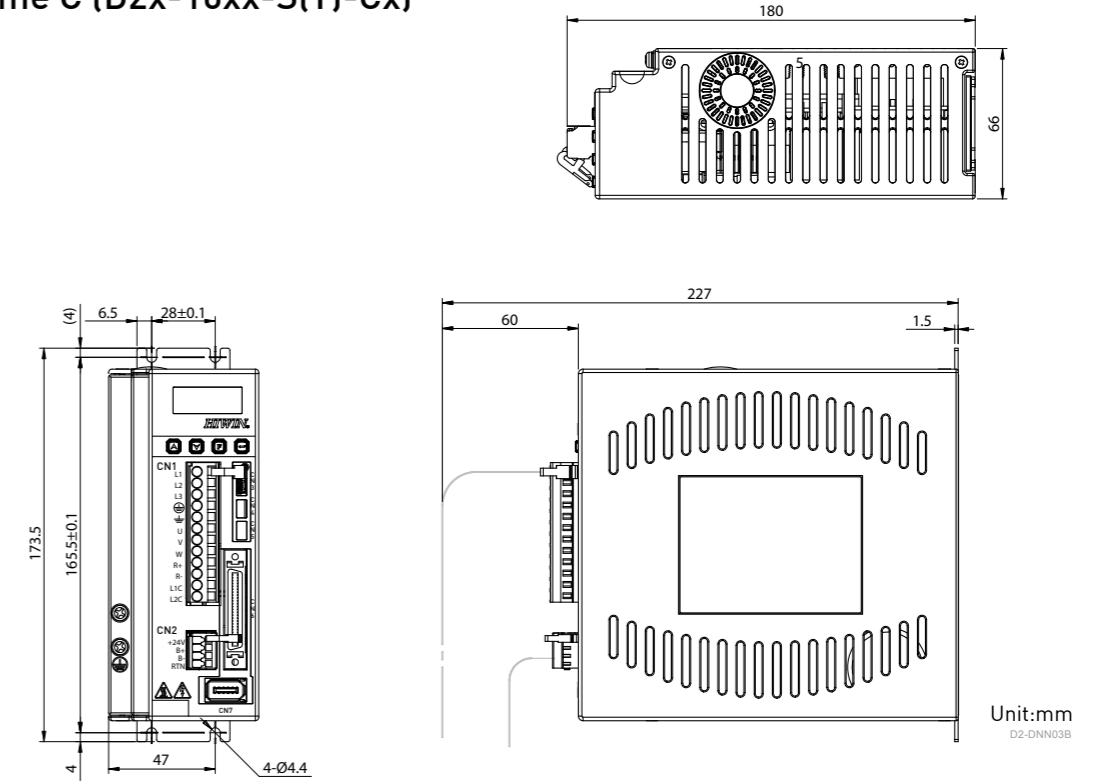

■ Frame B (D2x-04xx-S(T)-Bx)

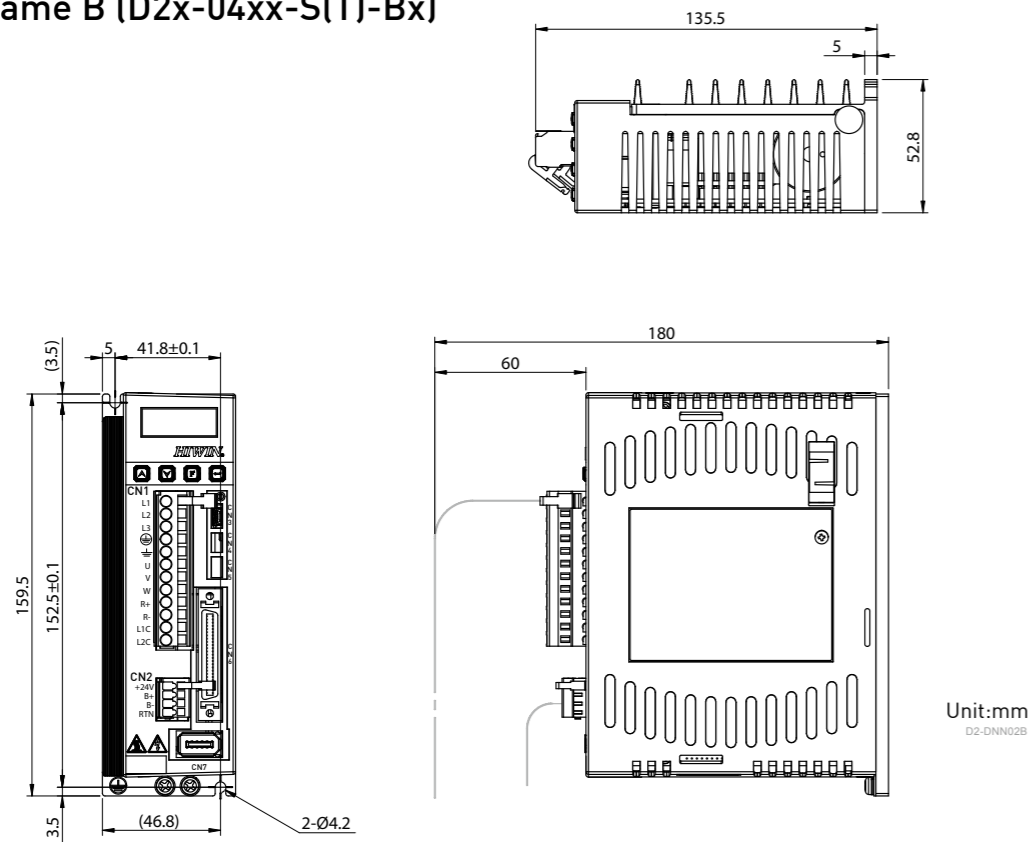

■ Frame D (D2x-20xx-S(T)-Dx)

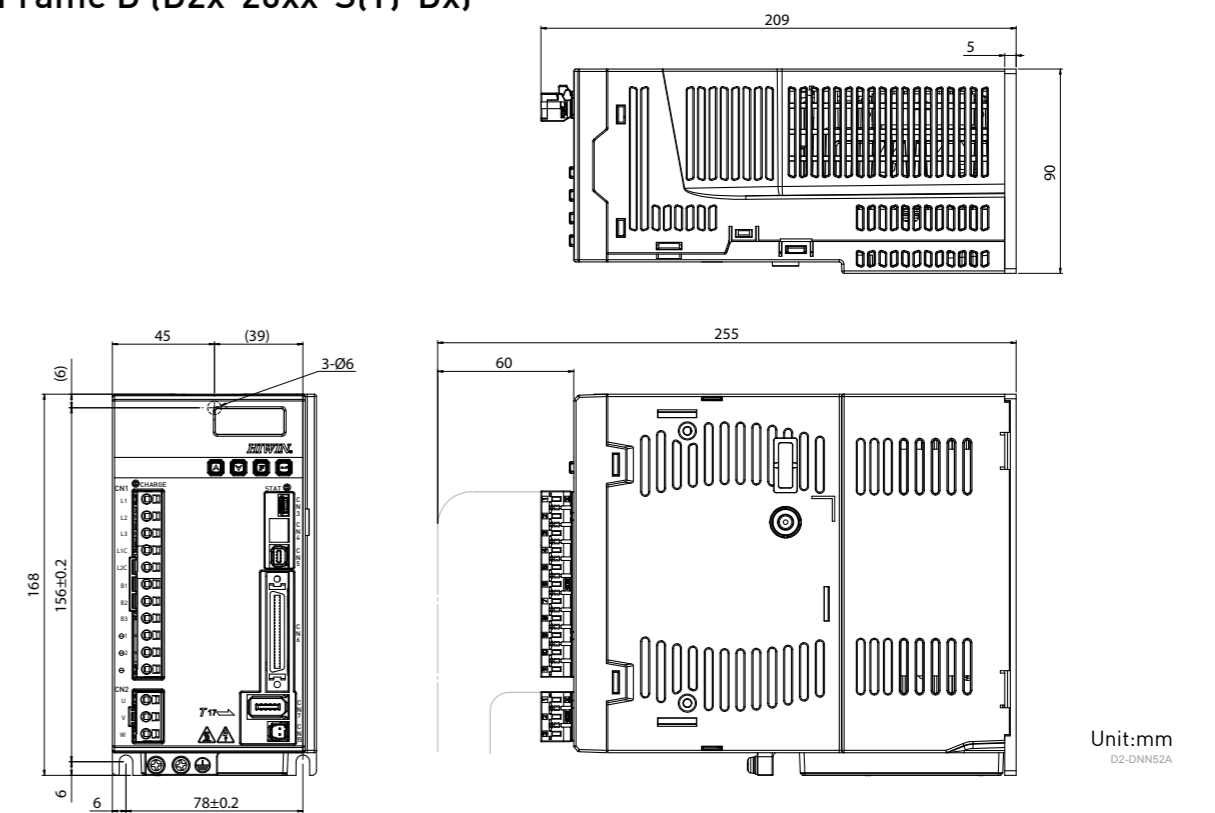

■ Frame A (D2x-01xx-E(Note)-Ax)

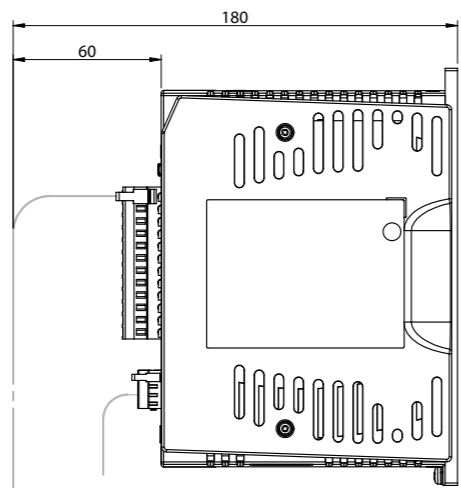
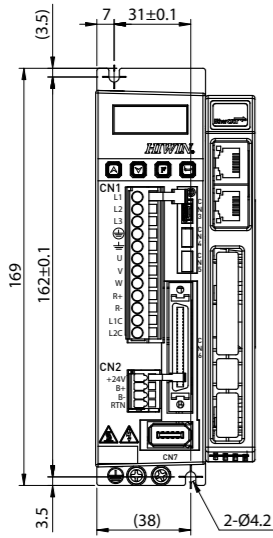
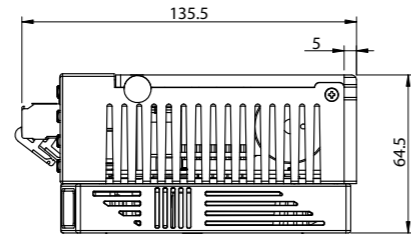

Unit:mm
D2-DNN49B

■ Frame C (D2x-10xx-E(Note)-Cx)

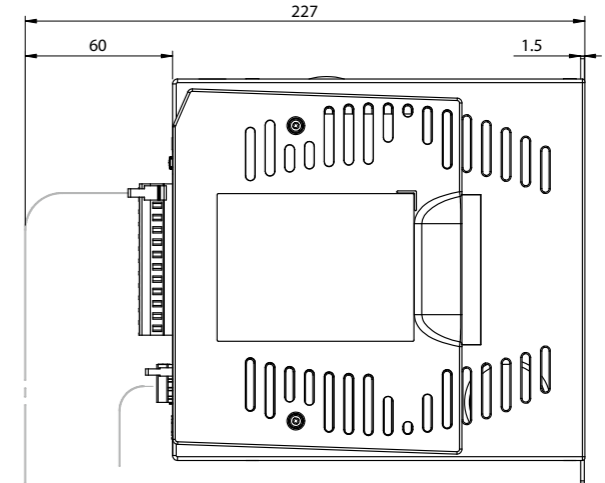
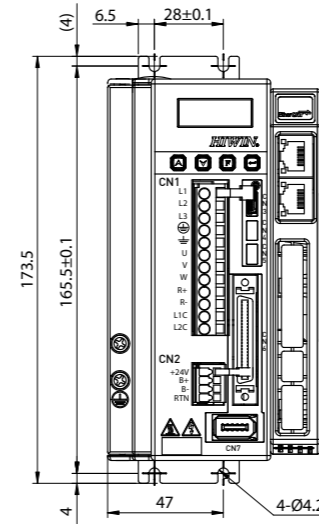
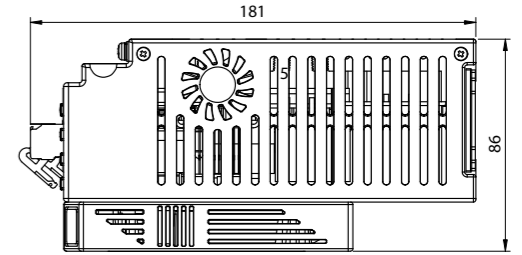

Unit:mm
D2-DNN51B

■ Frame B (D2x-04xx-E(Note)-Bx)

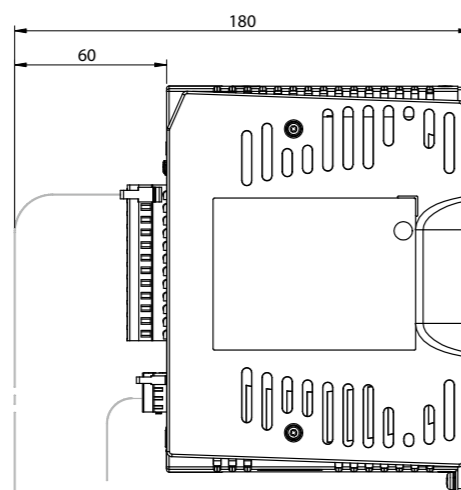
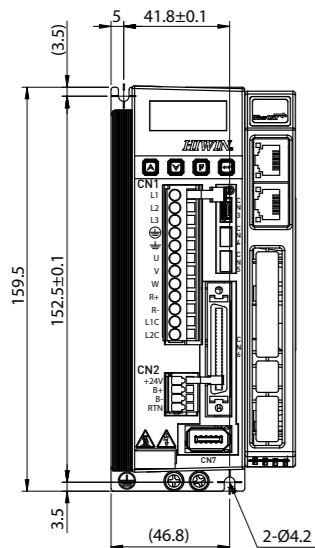
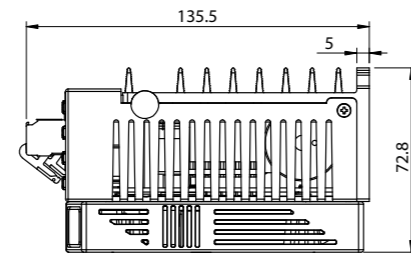

Unit:mm
D2-DNN50B

■ Frame D (D2x-20xx-E(Note)-Dx)

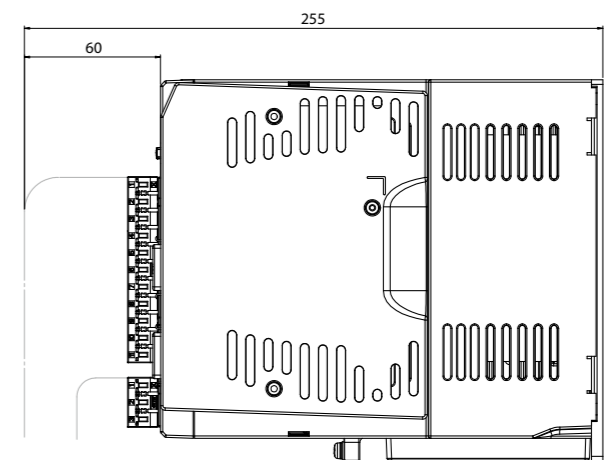
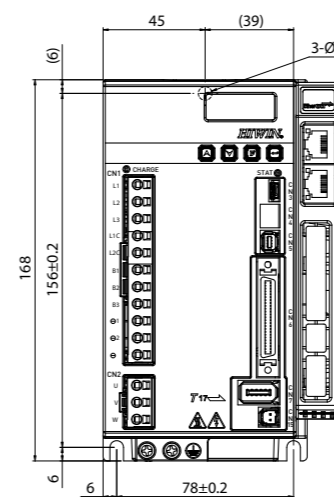
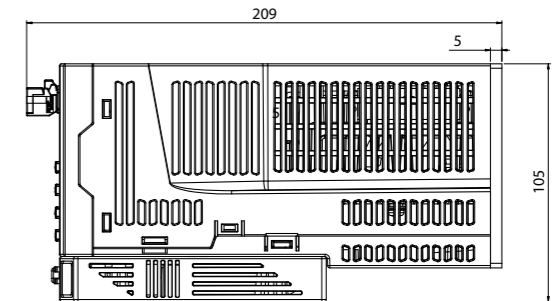

Unit:mm
D2-DNN53A

Note Interface E/F/K/U are plug-in module

6.5 Drive peripheral kits

■ Connector Kit

Part Name	Model	Description	Quantity
Frame A-C	D2-CK3	CN1 Main power, motor power, regenerative resistor and control power connector / 12pins, pitch5mm (051500400249)	1
		CN2 Brake connector: 4pins, pitch 3.5mm (051500400285)	1
		CN6 Control signal connector: 50 pins welded type(051500100127)	1
		CN1 Connector fixture tool (051800400035)	1
		CN2 Connector fixture tool (051800400066)	1
Frame D (with Modbus interface)	D2-CK4	CN1 Connectors of AC power, drive control power, regenerative resistor, and DC reactor. 11 pins, TE 1-2229794-1-PT1.	1
		CN2 Motor power connector. 3 pins, TE 3-22297894-1.	1
		CN4 Connector kit for serial communication. TE 2040008-1.	1
		CN5 Safety function connector. TE 1971153-1.	1
		CN6 Control signal connector. 50 pins, welded type, EUMAX XDR-10350AS.	1
		CN1 CN2 Connector fixture tools: TE 1981045-1.	2
Frame D	D2-CK5	CN1 Connectors of AC power, drive control power, regenerative resistor, and DC reactor. 11 pins, TE 1-2229794-1-PT1.	1
		CN2 Motor power connector. 3 pins,TE 3-22297894-1.	1
		CN5 Safety function connector. TE 1971153-1.	1
		CN6 Control signal connector. 50 pins welded type, EUMAX XDR-10350AS.	1
		CN1 CN2 Connector fixture tools: TE 1981045-1.	2

■ EMC Accessory Kit

Part Name	Model	Description	Quantity
D2 EMC accessory kit for single phase	D2-EMC1 (051800200074)	Single phase filter FN2090-6-06 for 50W to 400W (Rated current:6A, leakage current: 0.67mA)	1
		EMI core KCF-130-B	2
	D2-EMC3 (051800200077)	Single phase filter FN2090-10-06 for 750W and 1000W (Rated current:10A, leakage current: 0.67mA)	1
		EMI magnet rings KCF-130-B	2
D2 EMC accessory kit for three phase	D2-EMC2 (051800200075)	Three phase filter FN3025HL-20-71 (Rated current:20A, leakage current:0.4mA)	1
		EMI magnet rings KCF-130-B	2
	D2-EMC4 (051800200078)	Three phase filter B84743C0035R166 (Rated current:35A, leakage current: <0.5mA)	1
		EMI magnet rings KCF-130-B	2

EMI magnetic rings are applied on main power cables, motor power cables, encoder wires or pulse control wires respectively.

- ! 1. The leakage current of some models' noise filters is large. Therefore the leakage current will increase due to the ground conditions. When applying leak detectors and leakage circuit breakers, please consider on the basis of ground conditions and noise filters issues how to select. Please contact noise filter manufacturers for details.
2. The filter can be connected to more than one drive if the total maximum load current does not exceed the rated current.

7. Servo Motor

7.1 Motor specifications and application environment

Regenerative Resistor

Part Name	Model	Description	L1	L2	W	H	L
Regenerative resistor	RG1	68Ω Rated power 100W Peak power 500W (050100700001)	165 ± 2	150 ± 2	40 ± 0.5	40 ± 0.5	500
	RG2	120Ω Rated power 300W Peak power 1500W (050100700009)	215 ± 2	200 ± 2	60 ± 0.5	30 ± 0.5	500

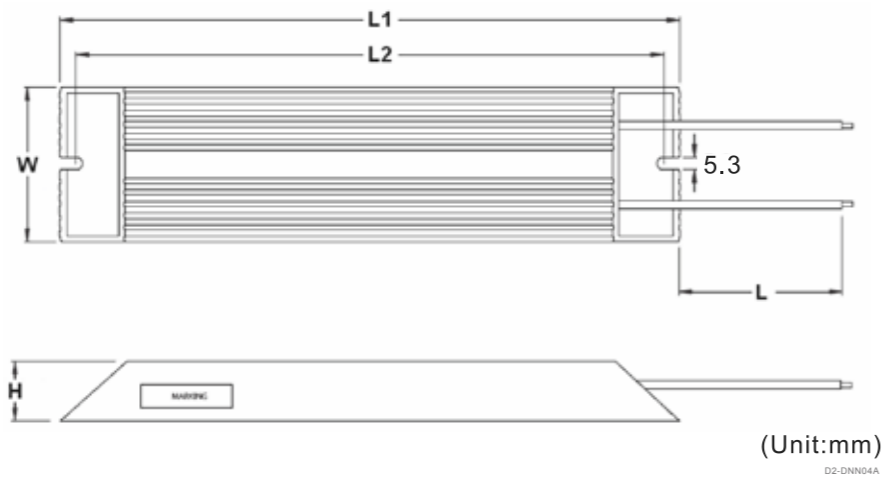











Common Mode Filter

Part Name	Model	Description	Quantity
Common mode filter	MF-CM-S (FF000MF11002)	Common mode inductance: 1100 μ H (nominal) for 50W to 2000W (Voltage maximum: 373Vdc, Rated current: 11Arms)	1

DC Reactor

Part Name	Model	Description	Quantity
DC Reactor	B86732G15L712 (051800200126)	1-phase DC reactor for 2000W Rated Voltage : 440Vdc Rated current : 14.2A Inductance: 2.45mH(nominal)	1

Motor	Rated output (W)	Voltage	Rated speed (No-load maximum speed) (rpm)	Encoder	IP level	Application	Environment	
Low Inertia FRLS	 D2-PPN02A	220V	3000 (4500)	13bit/17bit	IP65	Semiconductor Equipment Packaging Machine SMT Machine Food industry machine LCD equipment	<ul style="list-style-type: none"> Storage condition <ul style="list-style-type: none"> - Indoor illumination - Keep away from following environment <ul style="list-style-type: none"> a. corrosive gases b. flammable gas c. grease and dirt Application temperature 0 ° C ~ 40 ° C Storage Temperature -15 ° C ~ 70 ° C Humidity 80% RH or less Storage humidity 80% RH or less Elevation above sea level 1000m under Vibration resistance 49m/s² or less 	
	 D2-PPN03A							50W
	 D2-PPN04A							100W
	 D2-PPN05A							200W
	400W							

Motor	Rated output (W)	Voltage	Rated speed (No-load maximum speed) (rpm)	Encoder	IP level	Application	Environment	
FRMS		220V	3000 (4500)	17bit	IP65	Semiconductor Equipment Packaging Machine SMT Machine Food industry machine LCD equipment	<ul style="list-style-type: none"> Storage condition <ul style="list-style-type: none"> - Indoor illumination - Keep away from following environment <ul style="list-style-type: none"> a. corrosive gases b. flammable gas c. grease and dirt Application temperature <ul style="list-style-type: none"> 0 °C ~ 40 °C Storage Temperature <ul style="list-style-type: none"> -15 °C ~ 70 °C Humidity <ul style="list-style-type: none"> 80% RH or less Storage humidity <ul style="list-style-type: none"> 80% RH or less Elevation above sea level <ul style="list-style-type: none"> 1000m under Vibration resistance <ul style="list-style-type: none"> 49m/s² or less 	
								50W
								100W
	 D2-PPN06A							400W
FRMM	 D2-PPN07A	220V	2000 (3000)	13bit/17bit	IP65	Machine Tools Conveyor Equipment Textile Machine Mechanical arm		
	 D2-PPN11A							750W
				1000W				

7.2 Low inertia, Small capacity

7.2.1 50W

Parameter	Symbol	Unit	FRLS052□□A4□
Drive Input Voltage	V	V	AC220
Rated Power	W	W	50
Rated Torque	Tc	N.m	0.16
Rated Current	Ic	A(rms)	0.9
Peak Max. Torque	Tp	N.m	0.48
Peak Max. Current	Ip	A(rms)	2.7
Rated Speed	ω_c	rpm	3000
Max. Speed	ω_p	rpm	4500
Torque Constant	Kt	N.m / Arms	0.178
Back EMF Constant	Ke	Vrms / krpm	10.74
Resistance (line to line)	R	Ω	4.7
Inductance (line to line)	L	mH	4.7
Inertia of Rotating Parts (with brake)	J	kg-m ² ($\times 10^{-4}$)	0.02(0.022)
Weight (with brake)	M	kg	0.45(0.58)
Motor Insulation Grade	Class A (UL)		
Motor protect	Total enclosed, self-cooled, IP65 (Except for shaft and connector)		
Insulation resistance	10M Ω , DC500V		
Insulation voltage resistance	AC1500V, 60 second		

Brake specifications (Note 1)

Static friction torque (Minimum)	Tb	N.m	0.3
Magnetizing current	Ab	A	0.25A
Brake input voltage	V	V	DC24 \pm 10%
Suction time (Maximum)	to	ms	30
Release time (Maximum)	tr	ms	20

Note 1 Brakes are for maintaining object stop. Do not apply for deceleration, dynamic braking or emergency stop. Brake suction and release times vary with different circuitries, please note the actual operation delay time during application.

Torque-Speed Curve

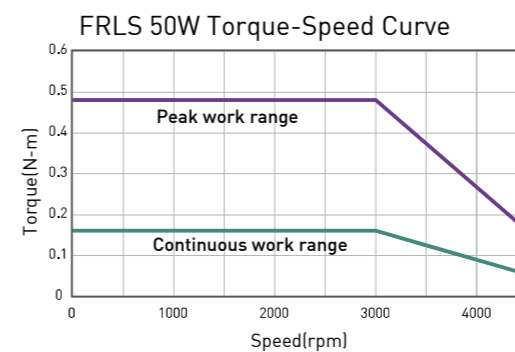

Dimensions

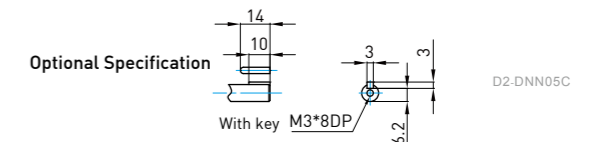
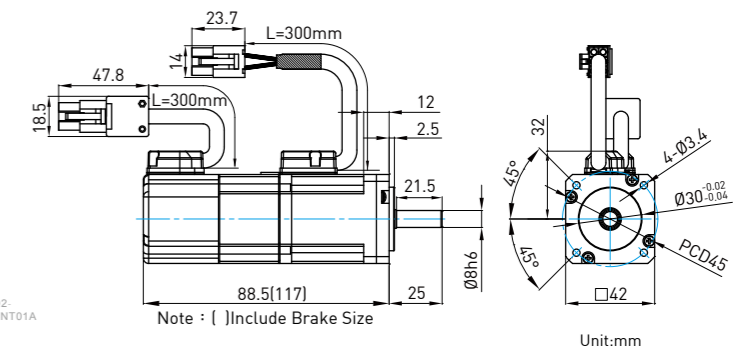

7.2.2 100W

Parameter	Symbol	Unit	FRLS102□□A4□
Drive Input Voltage	V	V	AC220
Rated Power	W	W	100
Rated Torque	Tc	N.m	0.32
Rated Current	Ic	A(rms)	0.9
Peak Max. Torque	Tp	N.m	0.96
Peak Max. Current	Ip	A(rms)	2.7
Rated Speed	ω_c	rpm	3000
Max. Speed	ω_p	rpm	4500
Torque Constant	Kt	N.m / Arms	0.356
Back EMF Constant	Ke	Vrms / krpm	21.98
Resistance (line to line)	R	Ω	8
Inductance (line to line)	L	mH	8.45
Inertia of Rotating Parts (with brake)	J	kg·m ² (×10 ⁻⁴)	0.036(0.038)
Weight (with brake)	M	kg	0.63(0.76)
Motor Insulation Grade	Class A (UL)		
Motor protect	Total enclosed, self-cooled, IP65 (Except for shaft and connector)		
Insulation resistance	10M Ω , DC500V		
Insulation voltage resistance	AC1500V, 60 second		

Brake specifications (Note 1)

Static friction torque (Minimum)	Tb	N.m	0.3
Magnetizing current	Ab	A	0.25A
Brake input voltage	V	V	DC24±10%
Suction time (Maximum)	to	ms	30
Release time (Maximum)	tr	ms	20

Note 1 Brakes are for maintaining object stop. Do not apply for deceleration, dynamic brakeing or emergency stop. Brake suction and release times vary with different circuitries, please note the actual operation delay time during application.

Torque-Speed Curve

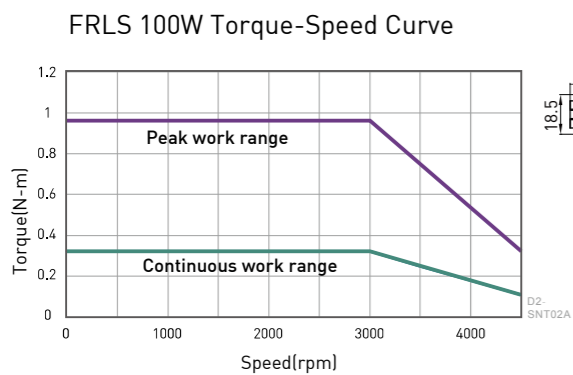

Dimensions

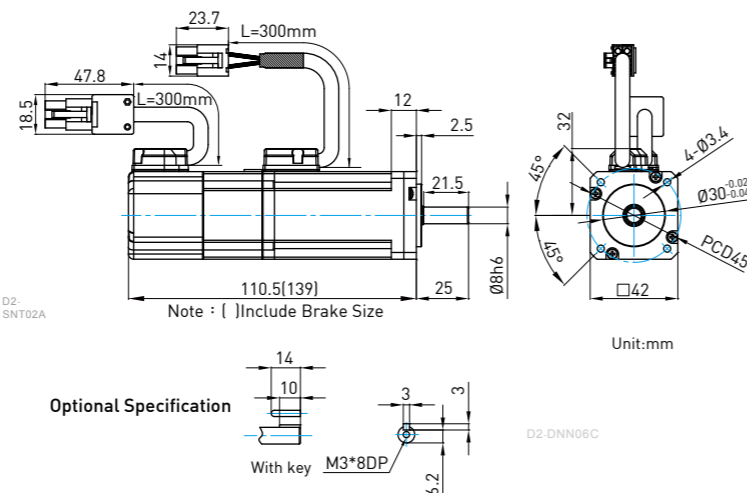

7.2.3 200W

Parameter	Symbol	Unit	FRLS202□□06□
Drive Input Voltage	V	V	AC220
Rated Power	W	W	200
Rated Torque	Tc	N.m	0.64
Rated Current	Ic	A(rms)	1.7
Peak Max. Torque	Tp	N.m	1.92
Peak Max. Current	Ip	A(rms)	5.1
Rated Speed	ω_c	rpm	3000
Max. Speed	ω_p	rpm	4500
Torque Constant	Kt	N.m / Arms	0.38
Back EMF Constant	Ke	Vrms / krpm	23
Resistance (line to line)	R	Ω	4.3
Inductance (line to line)	L	mH	13
Inertia of Rotating Parts (with brake)	J	kg·m ² (×10 ⁻⁴)	0.17(0.21)
Weight (with brake)	M	kg	0.95(1.5)
Motor Insulation Grade	Class A (UL)		
Motor protect	Total enclosed, self-cooled, IP65 (Except for shaft and connector)		
Insulation resistance	10M Ω , DC500V		
Insulation voltage resistance	AC1500V, 60 second		

Brake specifications (Note 1)

Static friction torque (Minimum)	Tb	N.m	1.3
Magnetizing current	Ab	A	0.32A
Brake input voltage	V	V	DC24±10%
Suction time (Maximum)	to	ms	30
Release time (Maximum)	tr	ms	20

Note 1 Brakes are for maintaining object stop. Do not apply for deceleration, dynamic brakeing or emergency stop. Brake suction and release times vary with different circuitries, please note the actual operation delay time during application.

Torque-Speed Curve

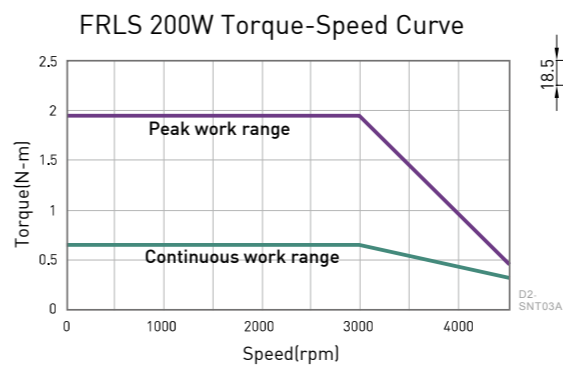

Dimensions

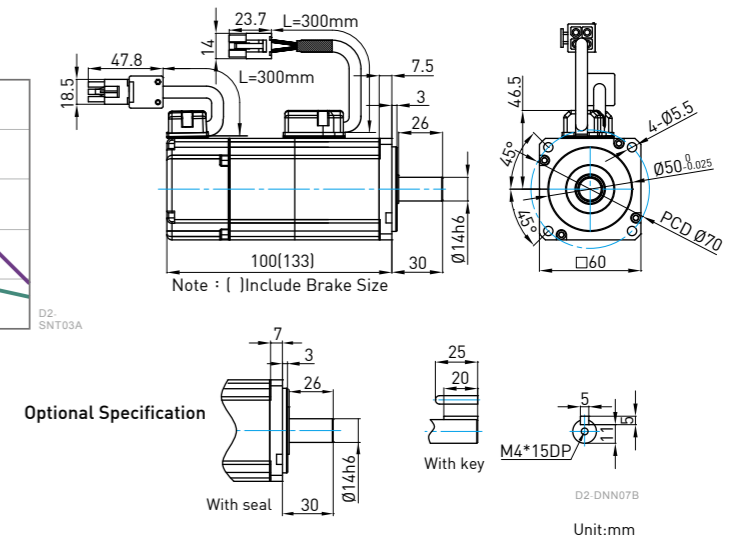

7.2.4 400W

Parameter	Symbol	Unit	FRLS402□□06□
Drive Input Voltage	V	V	AC220
Rated Power	W	W	400
Rated Torque	Tc	N.m	1.27
Rated Current	Ic	A(rms)	2.5
Peak Max. Torque	Tp	N.m	3.81
Peak Max. Current	Ip	A(rms)	7.5
Rated Speed	ω_c	rpm	3000
Max. Speed	ω_p	rpm	4500
Torque Constant	Kt	N.m / Arms	0.51
Back EMF Constant	Ke	Vrms / krpm	31.9
Resistance (line to line)	R	Ω	3.5
Inductance (line to line)	L	mH	13
Inertia of Rotating Parts (with brake)	J	kg-m ² ($\times 10^{-4}$)	0.27 (0.31)
Weight (with brake)	M	kg	1.31(1.86)
Motor Insulation Grade	Class A (UL)		
Motor protect	Total enclosed, self-cooled, IP65 (Except for shaft and connector)		
Insulation resistance	10M Ω , DC500V		
Insulation voltage resistance	AC1500V, 60 second		

Brake specifications (Note 1)

Static friction torque (Minimum)	Tb	N.m	1.3
Magnetizing current	Ab	A	0.32A
Brake input voltage	V	V	DC24 \pm 10%
Suction time (Maximum)	to	ms	30
Release time (Maximum)	tr	ms	20

Note 1 Brakes are for maintaining object stop. Do not apply for deceleration, dynamic brakeing or emergency stop. Brake suction and release times vary with different circuitries, please note the actual operation delay time during application.

Torque-Speed Curve

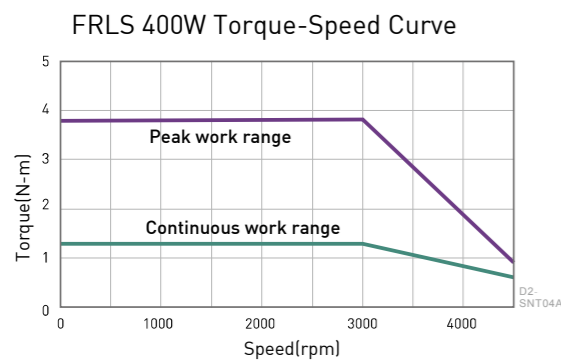

Dimensions

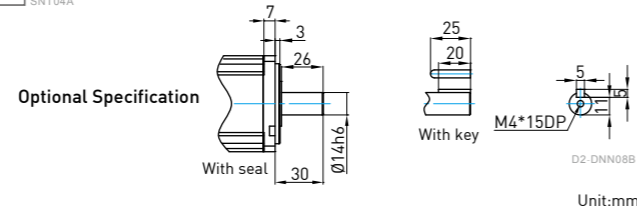
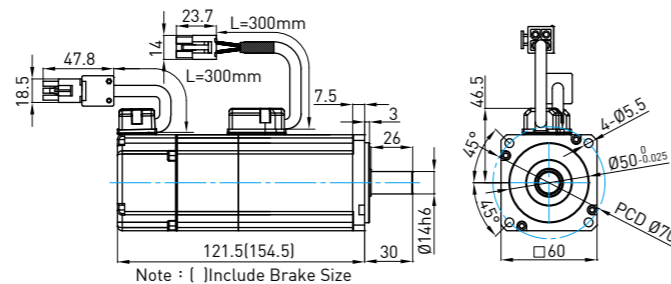

Unit:mm

7.3 Middle inertia, Small capacity

7.3.1 50W

Parameter	Symbol	Unit	FRMS052□□04□
Drive Input Voltage	V	V	AC220
Rated Power	W	W	50
Rated Torque	Tc	N.m	0.16
Rated Current	Ic	A(rms)	0.9
Peak Max. Torque	Tp	N.m	0.48
Peak Max. Current	Ip	A(rms)	2.7
Rated Speed	ω_c	rpm	3000
Max. Speed	ω_p	rpm	4500
Torque Constant	Kt	N.m / Arms	0.178
Back EMF Constant	Ke	Vrms / krpm	11.51
Resistance (line to line)	R	Ω	13.17
Inductance (line to line)	L	mH	11.75
Inertia of Rotating Parts (with brake)	J	kg-m ² ($\times 10^{-4}$)	0.025(0.027)
Weight (with brake)	M	kg	0.38(0.51)
Motor Insulation Grade	Class A (UL)		
Motor protect	Total enclosed, self-cooled, IP65 (Except for shaft and connector)		
Insulation resistance	10M Ω , DC500V		
Insulation voltage resistance	AC1500V, 60 second		

Brake specifications (Note 1)

Static friction torque (Minimum)	Tb	N.m	0.32
Magnetizing current	Ab	A	0.25A
Brake input voltage	V	V	DC24 \pm 10%
Suction time (Maximum)	to	ms	40
Release time (Maximum)	tr	ms	20

Note 1 Brakes are for maintaining object stop. Do not apply for deceleration, dynamic brakeing or emergency stop. Brake suction and release times vary with different circuitries, please note the actual operation delay time during application.

Torque-Speed Curve

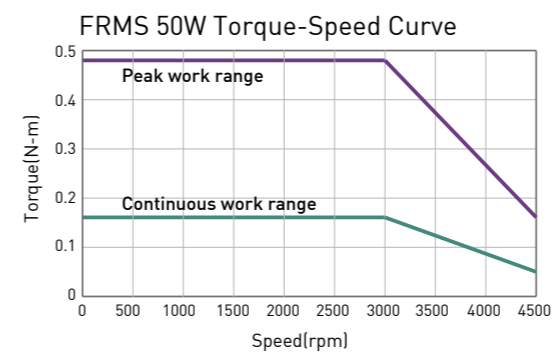

Dimensions

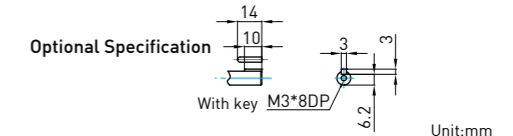
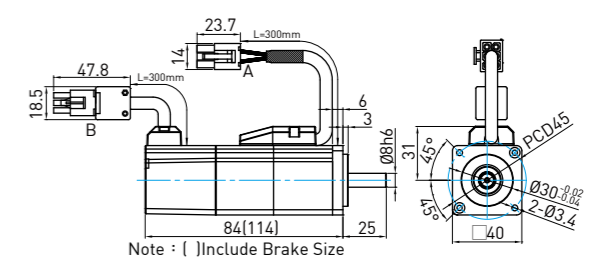

Unit:mm

7.3.2 100W

Parameter	Symbol	Unit	FRMS102□□04□
Drive Input Voltage	V	V	AC220
Rated Power	W	W	100
Rated Torque	Tc	N.m	0.32
Rated Current	Ic	A(rms)	0.9
Peak Max. Torque	Tp	N.m	0.96
Peak Max. Current	Ip	A(rms)	2.7
Rated Speed	ω_c	rpm	3000
Max. Speed	ω_p	rpm	4500
Torque Constant	Kt	N.m / Arms	0.356
Back EMF Constant	Ke	Vrms / krpm	20.93
Resistance (line to line)	R	Ω	19
Inductance (line to line)	L	mH	23.78
Inertia of Rotating Parts (with brake)	J	kg-m ² ($\times 10^{-4}$)	0.051(0.055)
Weight (with brake)	M	kg	0.54(0.67)
Motor Insulation Grade	Class A (UL)		
Motor protect	Total enclosed, self-cooled, IP65 (Except for shaft and connector)		
Insulation resistance	10M Ω , DC500V		
Insulation voltage resistance	AC1500V, 60 second		

Brake specifications (Note 1)

Static friction torque (Minimum)	Tb	N.m	0.32
Magnetizing current	Ab	A	0.25A
Brake input voltage	V	V	DC24 \pm 10%
Suction time (Maximum)	to	ms	40
Release time (Maximum)	tr	ms	20

Note 1 Brakes are for maintaining object stop. Do not apply for deceleration, dynamic braking or emergency stop. Brake suction and release times vary with different circuitries, please note the actual operation delay time during application.

■ Torque-Speed Curve

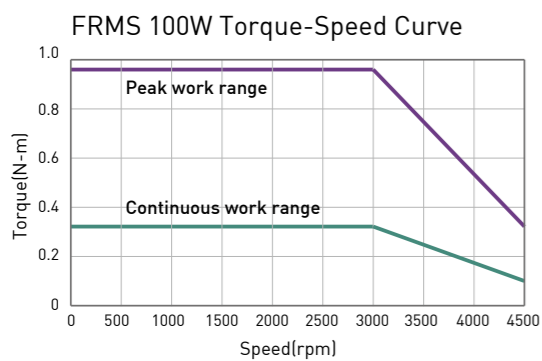

■ Dimensions

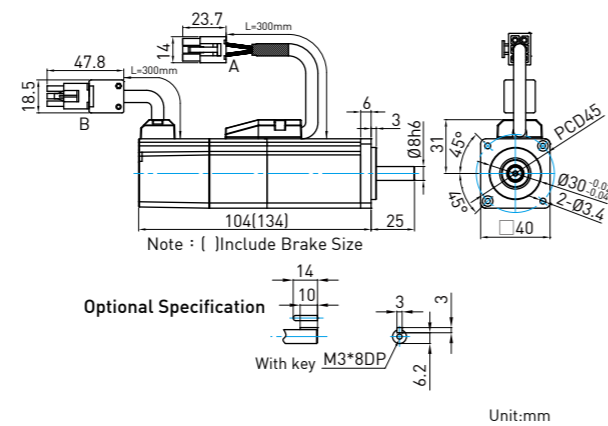

7.3.3 400W

Parameter	Symbol	Unit	FRMS4B2□□06□
Drive Input Voltage	V	V	AC220
Rated Power	W	W	400
Rated Torque	Tc	N.m	1.27
Rated Current	Ic	A(rms)	2.6
Peak Max. Torque	Tp	N.m	3.81
Peak Max. Current	Ip	A(rms)	7.8
Rated Speed	ω_c	rpm	3000
Max. Speed	ω_p	rpm	4500
Torque Constant	Kt	N.m / Arms	0.48
Back EMF Constant	Ke	Vrms / krpm	29.61
Resistance (line to line)	R	Ω	4.13
Inductance (line to line)	L	mH	9.9
Inertia of Rotating Parts (with brake)	J	kg-m ² ($\times 10^{-4}$)	0.44(0.48)
Weight (with brake)	M	kg	1.31(1.86)
Motor Insulation Grade	Class A (UL)		
Motor protect	Total enclosed, self-cooled, IP65 (Except for shaft and connector)		
Insulation resistance	10M Ω , DC500V		
Insulation voltage resistance	AC1500V, 60 second		

Brake specifications (Note 1)

Static friction torque (Minimum)	Tb	N.m	1.3
Magnetizing current	Ab	A	0.32
Brake input voltage	V	V	DC24 \pm 10%
Suction time (Maximum)	to	ms	30
Release time (Maximum)	tr	ms	20

Note 1 Brakes are for maintaining object stop. Do not apply for deceleration, dynamic braking or emergency stop. Brake suction and release times vary with different circuitries, please note the actual operation delay time during application.

■ Torque-Speed Curve

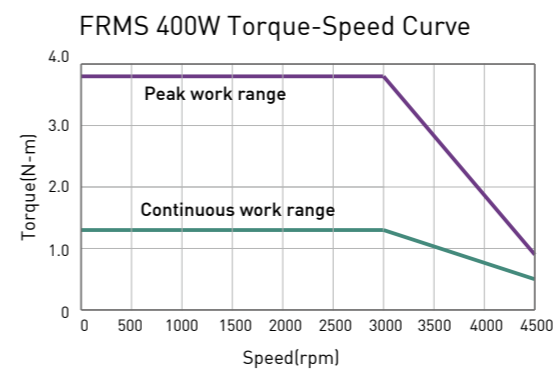

■ Dimensions

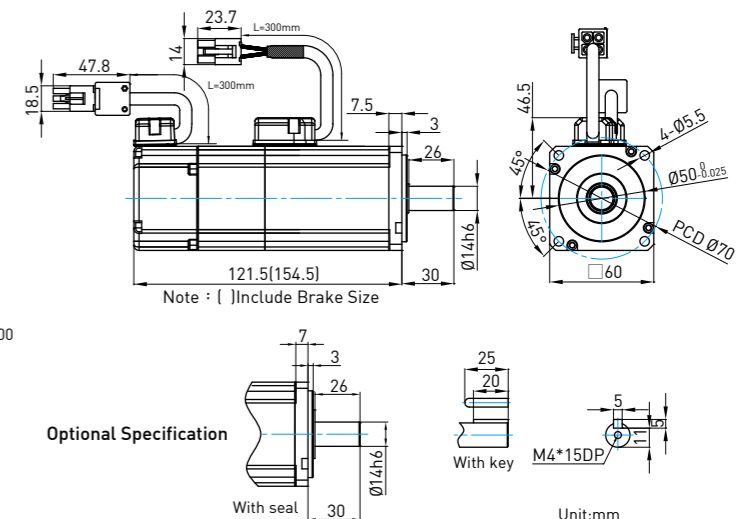

7.3.4 750W

Parameter	Symbol	Unit	FRMS752□□08□
Drive Input Voltage	V	V	AC220
Rated Power	W	W	750
Rated Torque	Tc	N.m	2.4
Rated Current	Ic	A(rms)	5.1
Peak Max. Torque	Tp	N.m	7.2
Peak Max. Current	Ip	A(rms)	15.3
Rated Speed	ω_c	rpm	3000
Max. Speed	ω_p	rpm	4500
Torque Constant	Kt	N.m / Arms	0.47
Back EMF Constant	Ke	Vrms / krpm	28.4
Resistance (line to line)	R	Ω	0.813
Inductance (line to line)	L	mH	3.4
Inertia of Rotating Parts (with brake)	J	kg-m ² ($\times 10^{-4}$)	1.4(1.46)
Weight (with brake)	M	kg	2.66(3.32)
Motor Insulation Grade	Class A (UL)		
Motor protect	Total enclosed, self-cooled, IP65 (Except for shaft and connector)		
Insulation resistance	10M Ω , DC500V		
Insulation voltage resistance	AC1500V, 60 second		

Brake specifications (Note 1)

Static friction torque (Minimum)	Tb	N.m	2.4
Magnetizing current	Ab	A	0.358A
Brake input voltage	V	V	DC24 \pm 10%
Suction time (Maximum)	to	ms	45
Release time (Maximum)	tr	ms	10

Note 1 Brakes are for maintaining object stop. Do not apply for deceleration, dynamic braking or emergency stop. Brake suction and release times vary with different circuitries, please note the actual operation delay time during application.

Torque-Speed Curve

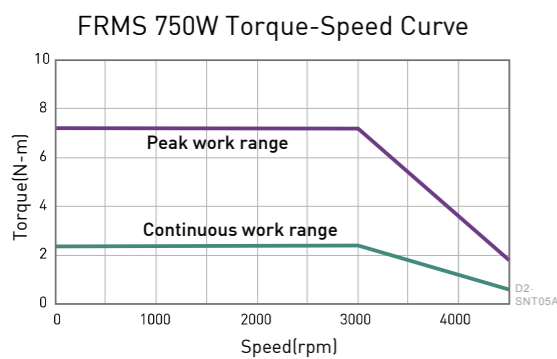

Dimensions

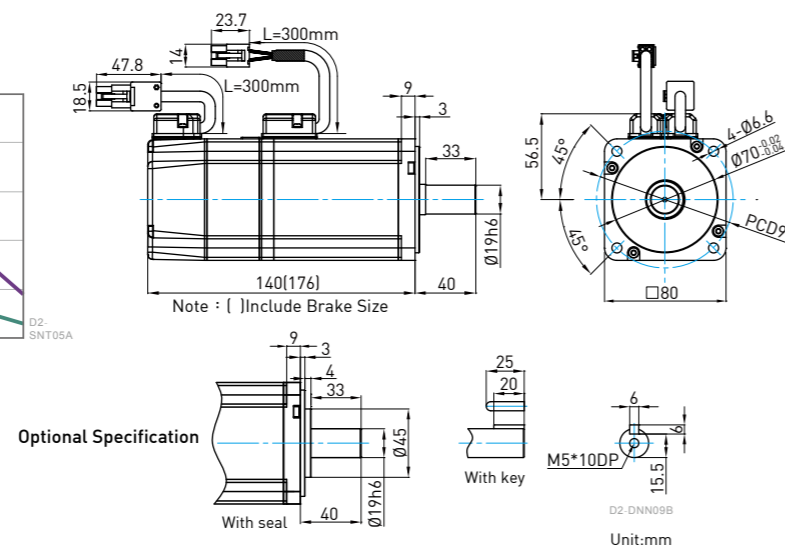

7.4 Middle inertia, Middle capacity

7.4.1 1000W

Parameter	Symbol	Unit	FRMM1K2□□13□
Drive Input Voltage	V	V	AC220
Rated Power	W	W	1000
Rated Torque	Tc	N.m	4.77
Rated Current	Ic	A(rms)	5.1
Peak Max. Torque	Tp	N.m	14.3
Peak Max. Current	Ip	A(rms)	15.3
Rated Speed	ω_c	rpm	2000
Max. Speed	ω_p	rpm	3000
Torque Constant	Kt	N.m / Arms	0.94
Back EMF Constant	Ke	Vrms / krpm	54.7
Resistance (line to line)	R	Ω	0.81
Inductance (line to line)	L	mH	8
Inertia of Rotating Parts (with brake)	J	kg-m ² ($\times 10^{-4}$)	7.6(8.7)
Weight (with brake)	M	kg	5.4(6.2)
Motor Insulation Grade	Class A (UL)		
Motor protect	Total enclosed, self-cooled, IP65 (Except for shaft and connector)		
Insulation resistance	10M Ω , DC500V		
Insulation voltage resistance	AC1500V, 60 second		

Brake specifications (Note 1)

Static friction torque (Minimum)	Tb	N.m	10
Magnetizing current	Ab	A	0.56A
Brake input voltage	V	V	DC24
Suction time (Maximum)	to	ms	80
Release time (Maximum)	tr	ms	30

Note 1 Brakes are for maintaining object stop. Do not apply for deceleration, dynamic braking or emergency stop. Brake suction and release times vary with different circuitries, please note the actual operation delay time during application.

Torque-Speed Curve

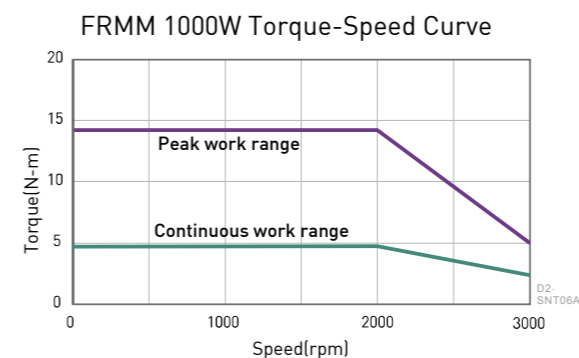

Dimensions

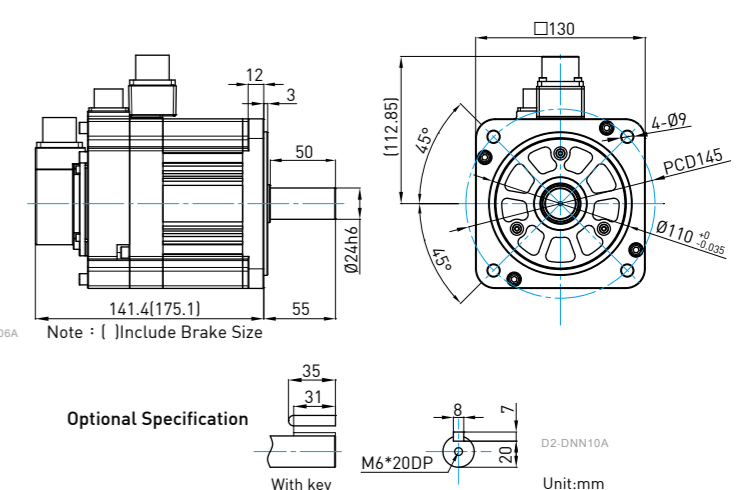

7.4.2 2000W

Parameter	Symbol	Unit	FRMM2K2□□13□
Drive Input Voltage	V	V	AC220
Rated Power	W	W	2000
Rated Torque	Tc	N.m	9.55
Rated Current	Ic	A(rms)	11
Peak Max. Torque	Tp	N.m	28.65
Peak Max. Current	Ip	A(rms)	33
Rated Speed	ω_c	rpm	2000
Max. Speed	ω_p	rpm	3000
Torque Constant	Kt	N.m / Arms	0.87
Back EMF Constant	Ke	Vrms / krpm	57.8
Resistance (line to line)	R	Ω	0.41
Inductance (line to line)	L	mH	3.7
Inertia of Rotating Parts (with brake)	J	kg·m ² ($\times 10^{-4}$)	13(14.1)
Weight (with brake)	M	kg	8(8.8)
Motor Insulation Grade	Class A (under certification)		
Motor protect	Total enclosed, self-cooled, IP65 (Except for shaft and connector)		
Insulation resistance	10M Ω , DC500V		
Insulation voltage resistance	AC1500V, 60 second		

Brake specifications (Note 1)

Static friction torque (Minimum)	Tb	N.m	10
Magnetizing current	Ab	A	0.56A
Brake input voltage	V	V	DC24
Suction time	to	ms	80
Release time	tr	ms	30

Note 1 Brakes are for maintaining object stop. Do not apply for deceleration, dynamic braking or emergency stop. Brake suction and release times vary with different circuitries, please note the actual operation delay time during application.

Torque-Speed Curve

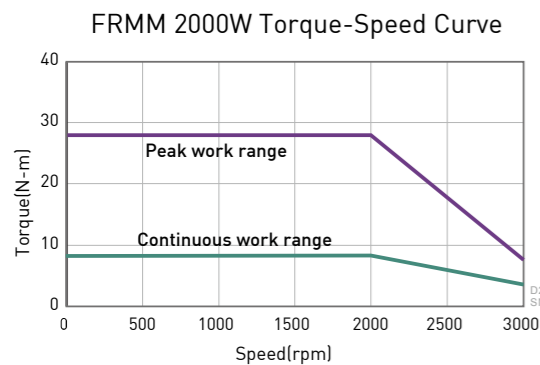

Dimensions

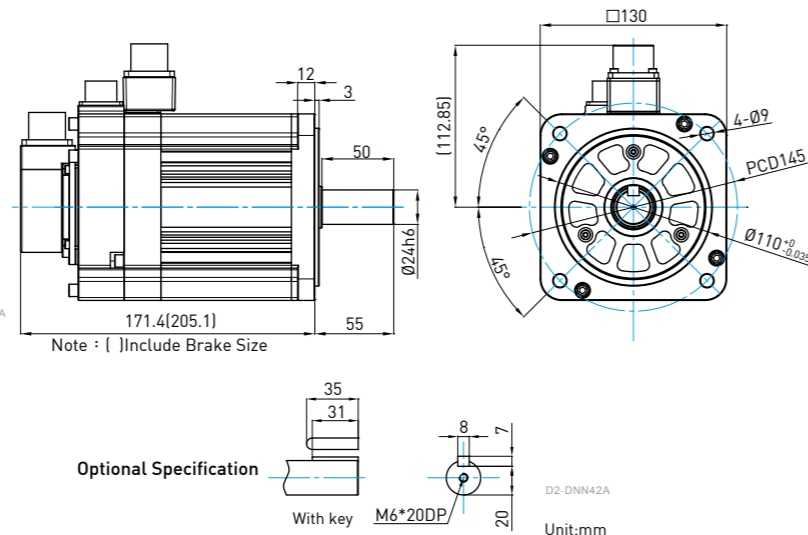

8. Cable and connector

8.1 Cable

Small Capacity

Name	Type	Connect	Description : 50W~750W
AC Servo Motor Power Cable	HVPS04AA□□□B	CN1	AMP-172159-1
AC Servo Motor Power and Brake Extension Cable	HVPS06AA□□□B	CN1 CN2	AMP-172160-1
AC Servo Motor Encoder Cable (13bit incremental)	HVE13IAB□□□B	CN7	AMP-172161-1
AC Servo Motor Encoder Cable (17bit incremental)	HVE17IAB□□□B		AMP-172161-9
AC Servo Motor Encoder Cable (17bit absolute)	HVE17AAB□□□B		AMP-1-172161-9

■ Middle Capacity – 1000W

Name	Type	Connect	Description : 1000W
AC Servo Motor Power Cable	HVPM04BA□□□B Straight Connector	CN1	
	HVPM04CA□□□B L-Type Connector		
AC Servo Motor Power Cable and Brake Cable (Note1)	HVPM06BA□□□B Straight Connector	CN1	
	HVPM06CA□□□B L-Type Connector		
	HVPM02BA□□□□		
	HVPM02CA□□□□		
AC Servo Motor Encoder Cable (13bit Incremental)	HVE13IBB□□□B Straight Connector		
	HVE13ICB□□□B L-Type Connector		
AC Servo Motor Encoder Cable (17bit incremental)	HVE17IBB□□□B Straight Connector	CN7	
	HVE17ICB□□□B L-Type Connector		
AC Servo Motor Encoder Cable (17bit absolute)	HVE17ABB□□□B Straight Connector		
	HVE17ACB□□□B L-Type Connector		

Note1 For middle capacity motors with brake, please remember to use power cable and brake cable simultaneously.

■ Middle Capacity – 2000W

Name	Type	Connect	Description : 2000W
AC Servo Motor Power Cable	HVPM04BB□□□B Straight Connector	CN1	
	HVPM04CB□□□B L-Type Connector		
AC Servo Motor Power Cable and Brake Cable (Note1)	HVPM06BB□□□B Straight Connector	CN1	
	HVPM06CB□□□B L-Type Connector		
	HVPM02BB□□□□		
	HVPM02CB□□□□		
AC Servo Motor Encoder Cable (17bit incremental)	HVE17IBB□□□B Straight Connector		
	HVE17ICB□□□B L-Type Connector		
AC Servo Motor Encoder Cable (17bit absolute)	HVE17ABB□□□B Straight Connector	CN7	
	HVE17ACB□□□B L-Type Connector		
	HE00817DR300(3m)		

Note1 For middle capacity motors with brake, please remember to use power cable and brake cable simultaneously.

AC Servo Dual loop Encoder Cable Specification · HE00817DR300(3m)

■ Communication and Interface Cable

Name	Type	Connect	
Mini USB Cable	051700800366	CN3	USB A type (2m) Mini USB D2-DNN25A
	HE00834S0800(0.3m)	CN4 / CN5	D2 Modbus Communication Cable(only for fram A,B,C) Specification : HE00834S0800(0.3m) · HE00834S0900(1m) · HE00834S1000(2m) · HE00834S1100(3m)
	HE00834S0900(1m)		
	HE00834S1000(2m)		
HE00834S1100(3m)			
Interface Cable	HE00815AC200	CN6	D2-DNN26A
IO Extension Cable	HE00834S1200(3m)	CN6	D2 Drive Extension IO Cable Specification : HE00834S1200(3m)

8.2 Connector

Small Capacity Series 50W~750W	Motor power cable connector (includes brake) Encoder connector D2-DNN27A
Middle Capacity Series 1000W/2000W	Motor power cable connector Brake power connector Encoder connector D2-DNN28A

■ Motor Power Connector

Small Capacity Series / 50W~750W

Signal	AMP-172167-1 (without brake)	AMP-172168-1 (with brake)
U	3	3
V	2	2
W	1	1
GND	4	4
B+	--	5
B-	--	6

Connect Pins Position Definition

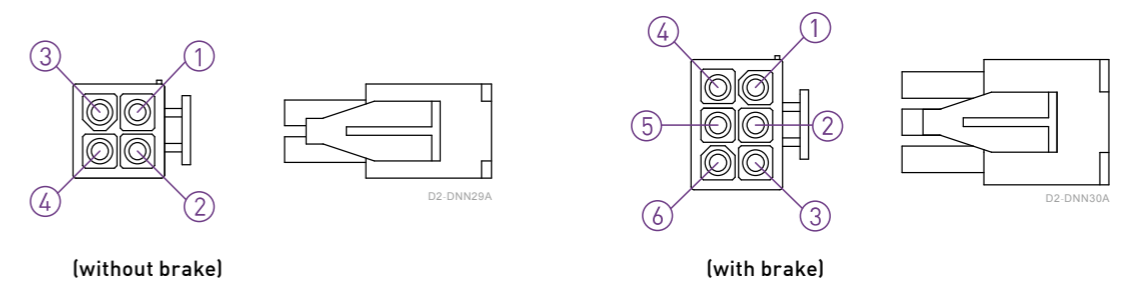

Middle Capacity Series /1000W · 2000W

Signal	WPS3102A18-10P-R	WPS3102A14S-7P-R
U	A	--
V	B	--
W	C	--
GND	D	--
B+	--	A
B-	--	C

Connect Pins Position Definition

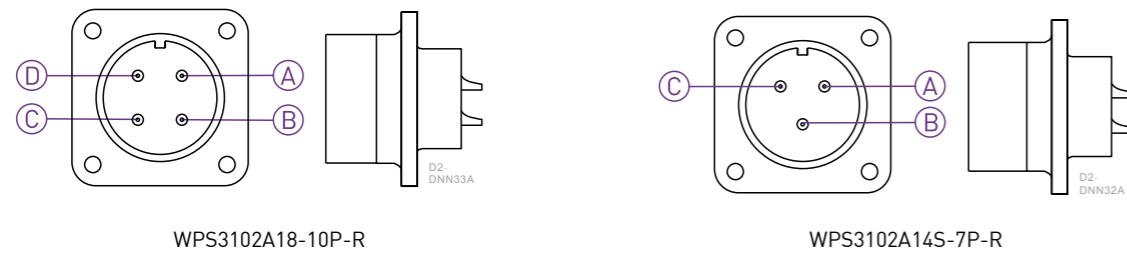

! By brake Type, two connectors must be used simultaneously

■ Encoder Connector

13bit Incremental / 50W~750W

Function	Signal	AMP-172169-1
Power	5V±5%	1
	0V	2
Incremental Signal/ Hall signal	A+ U+	3
	A- U-	4
	B+ V+	5
	B- V-	6
	Z+ W+	7
	Z- W-	8
Shielding	Shielding	9

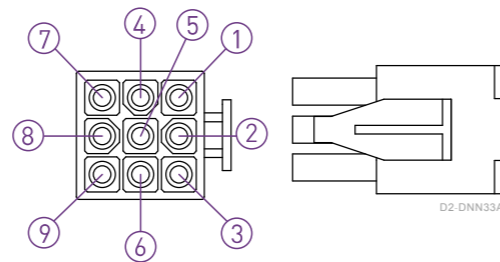

13bit Incremental / 1000W

Function	Signal	WPS3102A18-1P-R
Power	5V±5%	A
	0V	B
Incremental Signal/ Hall signal	A+ U+	C
	A- U-	D
	B+ V+	E
	B- V-	F
	Z+ W+	G
	Z- W-	H
Shielding	Shielding	I

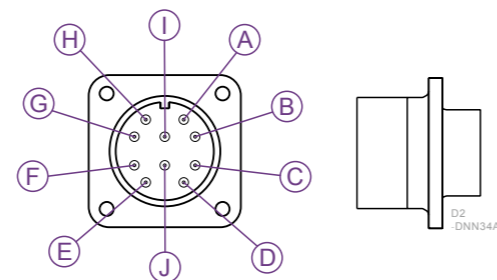

17bit incremental / 50W~750W

Function	Signal	AMP1-172169-9
Power	5V±5%	1
	0V	2
Serial Data Signal	SL+	3
	SL-	4
	MA+	7
	MA-	8
Shielding	Shielding	9

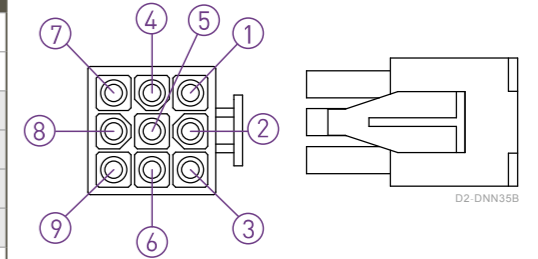

17bit incremental / 1000W · 2000W

Function	Signal	WPS3102A18-1P-R
Power	5V±5%	A
	0V	B
Serial Data Signal	SL+	C
	SL-	D
	MA+	G
	MA-	H
Shielding	Shielding	I

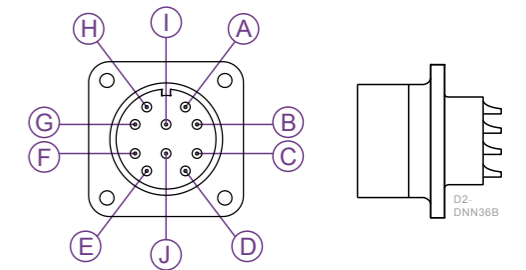

17bit absolute / 50W~750W

Function	Signal	AMP-1-172169-9
Power	5V	1
	0V	2
Battery	VB	5
	GND	6
Serial Data Signal	SD+	7
	SD-	8
Shielding	Shielding	9

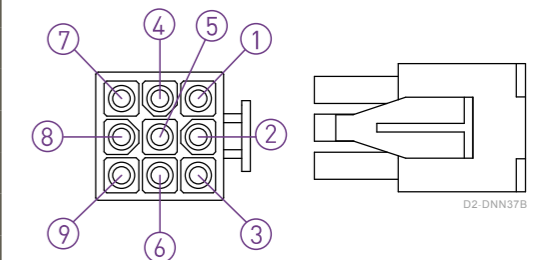

17bit absolute / 1000W · 2000W

Function	Signal	WPS3102A18-1P-R
Power	5V	A
	0V	B
Battery	VB	E
	GND	F
Serial Data Signal	SD+	G
	SD-	H
Shielding	Shielding	I

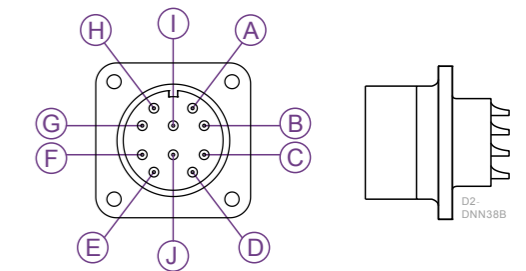

9. HIWIN single axis robot and motor adaptor flange

AC Servo Motor		HIWIN single axis robot							Drive
		KK40	KK50	KK60	KK80	KK86	KK100	KK130	
50W	FRLS052XXA4X	F2	F2	F2	F3	F3	F1	-	D2x-01xx-x-Ax
100W	FRLS102XXA4X	F2	F2	F2	F3	F3	-	-	D2x-01xx-x-Ax
200W	FRLS202XX06X	-	-	-	F0	F0	F0	F1	D2x-04xx-x-Bx
400W	FRLS402XX06X	-	-	-	F0	F0	F0	F1	D2x-04xx-x-Bx
750W	FRMS752XX08X	-	-	-	-	-	F1	F2	D2x-10xx-x-Cx

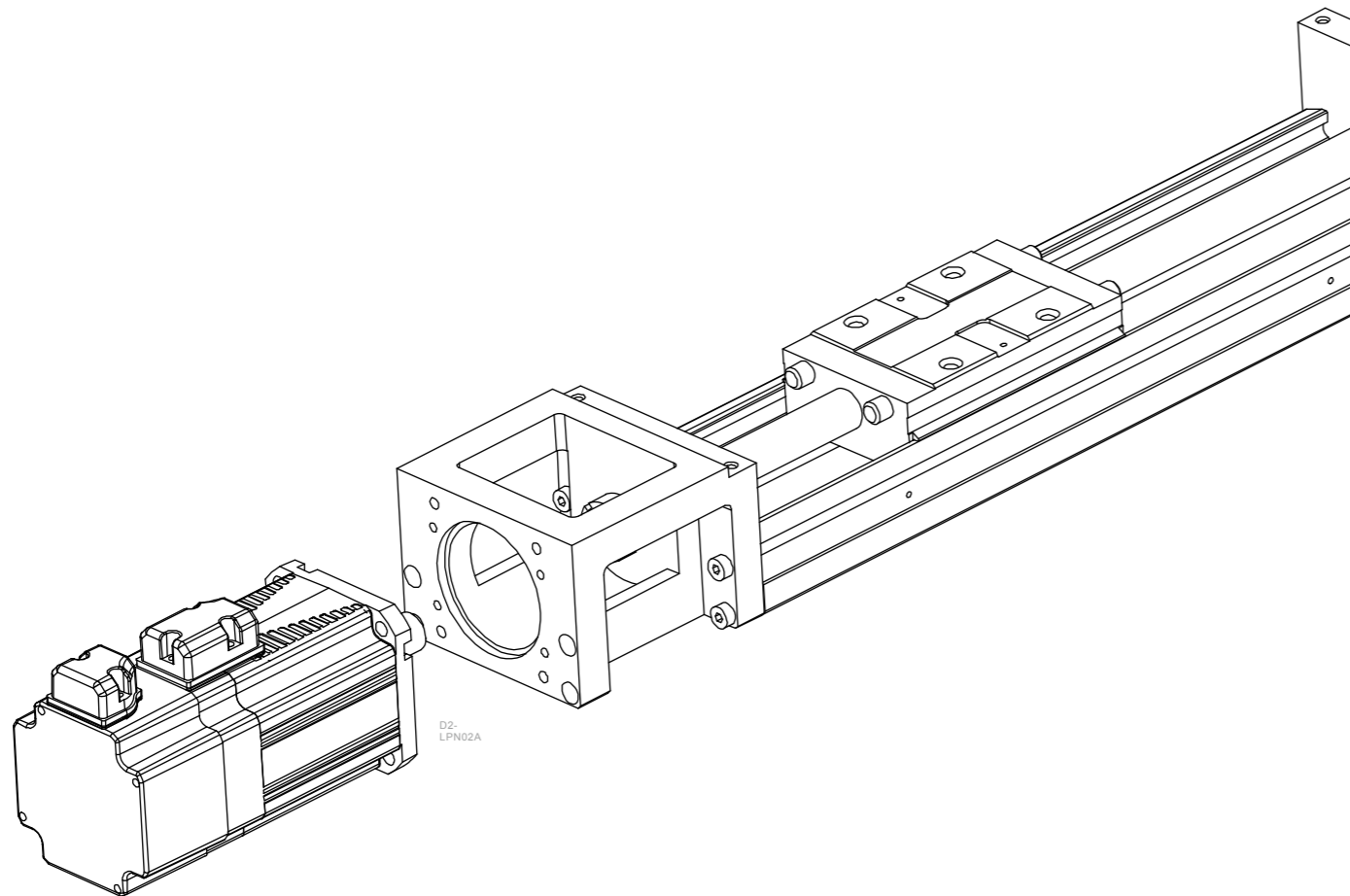

10. Servo Motor Selection Guide

The motor selection guide in this chapter is located on-line at <http://www.hiwinmikro.tw/hiwincal.aspx>

1. Definition of mechanism to be driven by the motor.

Define detailed dimensions of individual mechanical components (ex: ball screw length, lead and pulley diameter)

Typical servo mechanisms are listed as follows:

[Ball screw mechanism]

[Belt mechanism]

[Rack and pinion mechanism]

[Reduction gear mechanism]

2. Definition of operating pattern (motion velocity profile).

The operating pattern can be defined by the following parameters: acceleration/deceleration time, constant-velocity time, stop time, cycle time, travel distance.

3. Calculation of load inertia and motor inertia ratio.

Calculate load inertia for each mechanical component. (Refer to "General inertia calculation method" described later.)

Then, divide the calculated load inertia by the inertia of the selected motor then check the inertia ratio. Note that the ratio should less than 10, if the selected motor is less than 750W. If the power of selected motor is higher than 1000W, the ratio should less than 10.

4. Calculation of motor velocity.

Calculate the motor velocity from the moving distance, acceleration/deceleration time and constant-velocity time.

5. Calculation of torque.

Calculate the required motor torque from the load inertia, acceleration/deceleration time and constant-velocity time.

6. Calculation of motor

Select a motor that meets the above 3 to 5 requirements.

10.1 Introduction of motor selection relevant parameters

■ Peak torque

Peak torque indicates the maximum torque that the motor requires during operation (mainly in acceleration and deceleration steps). The reference value is 80% or less of the maximum motor torque. If the torque is a negative value, a regenerative discharge resistor may be required.

■ Traveling torque, stop holding torque

Traveling torque indicates the torque that the motor requires for a long time. Stop holding torque indicates that the amount of torque required for a motor to remain in a fixed position.

Traveling torque calculation formula for each mechanism.

List of symbol :

- W : Workpiece weight [kg]
- B_p : Lead [m]
- D : Pulley diameter [m]
- F : External force [N]
- B_{eff} : Mechanical efficiency
- μ : Coefficient of friction
- g : Acceleration of gravity 9.8[m/s²]

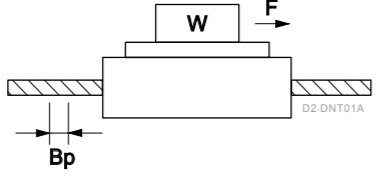

Traveling torque

$$T_f = \frac{B_p}{2\pi B_{eff}} (\mu g W + F)$$

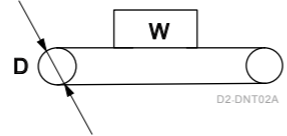

Traveling torque

$$T_f = \frac{D}{2\pi B_{eff}} (\mu g W + F)$$

■ Effective torque

Effective torque indicates a root-mean-square value of the total required for running and stopping the motor per unit time. The reference value is approximate 80% or less of the rated motor torque.

$$T_{rms} = \sqrt{\frac{T_a^2 \times t_a + T_f^2 \times t_b + T_d^2 \times t_d}{t_c}}$$

T_a: Acceleration torque [N-m]

T_f: Traveling torque [N-m]

T_d: Deceleration torque [N-m]

t_c: Cycle time [s] (Run time + Stop time)

t_a: Acceleration time [s]

t_b: constant-velocity time [s]

t_d: Deceleration time [s]

■ Motor velocity

Maximum velocity of motor in operation: The reference value is the rated velocity or lower value. When the motor operates at the maximum velocity, you must pay attention to the motor torque and temperature rise.

■ Load inertia and motor inertia ratio

Inertia is like the force to retain the current moving condition. Inertia ration is calculated by dividing load inertia by rotor inertia. Generally, for motor with 750W or lower capacity, the inertia ratio should be “10” or less. For motor with 1000W or higher capacity, the inertia ratio should be “10” or less. If the system need quicker response, a lower inertia ratio is required.

10.2 General inertia calculation for various rigid objects of uniform composition

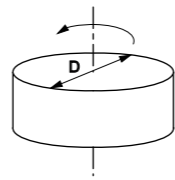
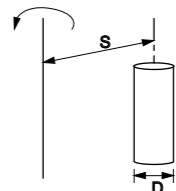
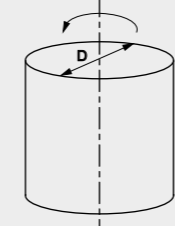
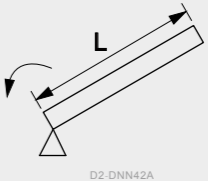
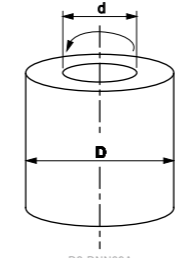
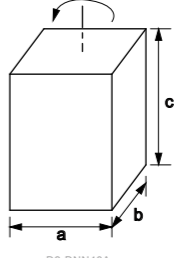
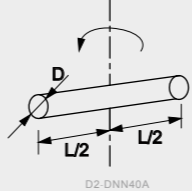
Shape	J calculation formula	Shape	J calculation formula
 <p style="text-align: center;">D2-DNN37A</p>	$J = \frac{1}{8} MD^2$	 <p style="text-align: center;">D2-DNN41A</p>	$J = \frac{1}{8} MD^2 + MS^2$
 <p style="text-align: center;">D2-DNN38A</p>	$J = \frac{1}{8} MD^2$	 <p style="text-align: center;">D2-DNN42A</p>	$J = \frac{1}{3} ML^2$
 <p style="text-align: center;">D2-DNN39A</p>	$J = \frac{1}{8} M(D^2 + d^2)$	 <p style="text-align: center;">D2-DNN43A</p>	$J = \frac{1}{12} M(a^2 + b^2)$
 <p style="text-align: center;">D2-DNN40A</p>	$J = \frac{1}{48} M(3D^2 + 4L^2)$		

List of symbol :

- J : Inertia [kg·m²]
- M : Mass [kg]
- D : Outer diameter [m]
- d : Inner diameter [m]
- L : Length [m]
- a, b, c : Side length [m]
- S : Distance [m]

If mass [M [kg]] is unknown, calculate it with the following formula :

Mass M[kg] = Density ρ [kg/m³] x Volume V[m³]

Density of each material

- Iron ρ = 7.9 x 10³ [kg/m³]
- Brass ρ = 8.5 x 10³ [kg/m³]
- Aluminum ρ = 2.8 x 10³ [kg/m³]

10.3 Equivalent inertia calculation for mechanism

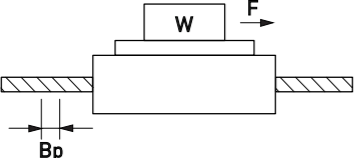
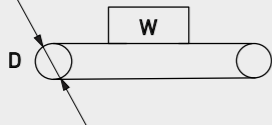
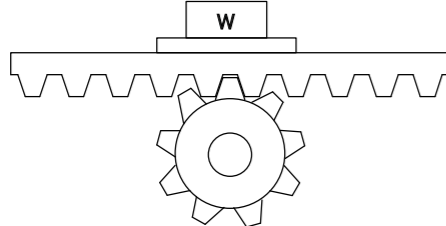
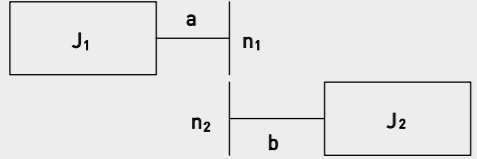
Mechanism	J calculation formula
Ball screw 	$J = J_B + \frac{MB_P^2}{4\pi^2}$
Belt(Conveyor) 	$J = \frac{1}{4} W_b D^2$ *Excluding drum J
Rack and pinion 	$J = J_p + (M_r + W_r) \frac{D^2}{4}$
Reduction gear 	$J = J_1 + \left(\frac{n_2}{n_1}\right)^2 J_2$ Inertia on shaft "a"

- List of symbol:
 J : Inertia [kg-m²]
 J_B : J of ball screw
 J_P : J of pinion
 M : Mass [kg]
 M_r : Mass of rack [kg]
 W_b : Workpiece weight on belt [kg]
 W_r : Workpiece weight on rack [kg]
 P : Lead
 D : Drum diameter [m]
 n₁ : A rotational speed of a shaft [r/min]
 n₂ : A rotational speed of b shaft [r/min]

10.4 Operating pattern (motion velocity profile)

■ Trapezoidal profile

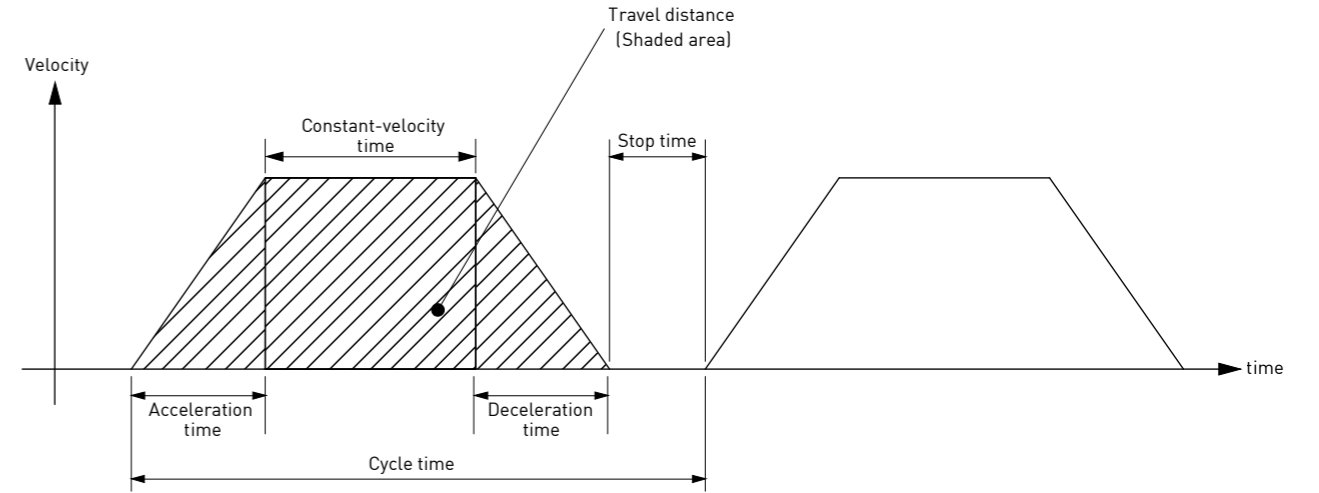

■ Triangle profile

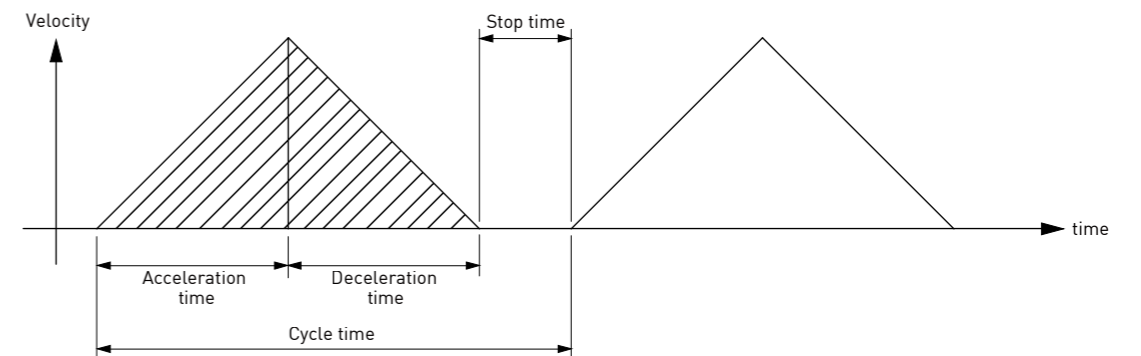

10.5 Motor selection example - ballscrews mechanism

Workpiece weight $W = 5$ [kg]
 Ball screw length $B_L = 0.5$ [m]
 Ball screw diameter $B_D = 0.02$ [m]
 Ball screw lead $B_p = 0.02$ [m]
 Ball screw efficiency $B_{eff} = 0.9$
 Travel distance 0.3 [m]
 Coupling inertia $J_C = 10 \times 10^{-6}$ [kg-m²]

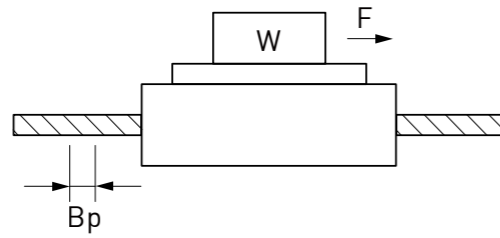

■ Running pattern(velocity profile)

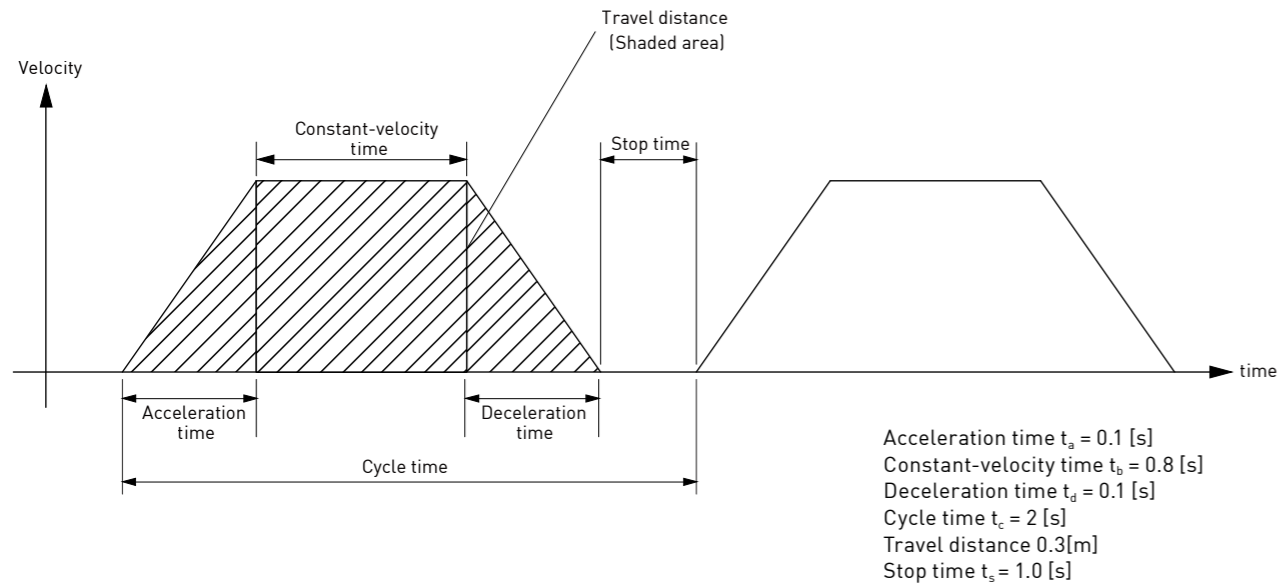

■ Ball screw weight

$$B_W = \rho \times \pi \times \left(\frac{B_D}{2}\right)^2 \times B_L$$

$$= 7.9 \times 10^3 \times \pi \times \left(\frac{0.02}{2}\right)^2 \times 0.5$$

$$= 1.24$$
 [kg]

■ Load inertia

$$J_L = J_C + J_B + J_W = J_C + \frac{1}{8} B_W \times B_D^2 + \frac{W \times B_p^2}{4 \pi^2}$$

$$= 0.00001 + \frac{1.24 \times 0.02^2}{8} + \frac{5 \times 0.02^2}{4 \pi^2}$$

$$= 1.226 \times 10^{-4}$$
 [kg-m²]

■ Provisional motor selection

Choose Hiwin 200W Servo motor : $J_M = 0.17 \times 10^{-4}$ [kg-m²]

■ Calculation of inertia ratio

$$\frac{J_L}{J_M} = \frac{1.226 \times 10^{-4}}{0.17 \times 10^{-4}} = 7.21$$

The inertia ratio is less than 10.

■ Calculation of maximum velocity (Vmax)

$$\frac{1}{2} \times t_a \times V_{max} + t_b \times V_{max} + \frac{1}{2} \times t_d \times V_{max} = \text{Travel distance}$$

$$\frac{1}{2} \times 0.1 \times V_{max} + 0.8 \times V_{max} + \frac{1}{2} \times 0.1 \times V_{max} = 0.3$$

$$V_{max} = 0.334$$
 [m/s]

■ Calculation of motor velocity (N [r/min])

Ball screw lead $B_p = 0.02$ [m]

$$N = \frac{V_{max}}{B_p} = \frac{0.334}{0.02} = 16.7$$
 [rps] = 1002 [rpm]

1002[rpm] is less than 3000[rpm] (rated velocity of Hiwin 200W Servo motor)

■ Calculation of torque

Traveling torque	$T_f = \frac{B_p}{2\pi B_{eff}} (\mu gW + F) = \frac{0.02}{2\pi \cdot 0.9} (0.1 \times 9.8 \times 5 + 0) = 0.017 \text{ [N-m]}$
Acceleration torque	$T_a = \frac{(J_L + J_M) \times \frac{2\pi N}{60}}{t_a} + T_f$ $= \frac{(1.226 \times 10^{-4} + 0.7 \times 10^{-4}) \times \frac{2\pi \times 1002}{60}}{0.1} + 0.017$ $= 0.163 \text{ [N-m]}$
Deceleration torque	$T_d = \frac{(J_L + J_M) \times \frac{2\pi N}{60}}{t_d} - T_f$ $= \frac{(1.226 \times 10^{-4} + 0.7 \times 10^{-4}) \times \frac{2\pi \times 1002}{60}}{0.1} - 0.017$ $= 0.129 \text{ [N-m]}$

■ Verification of maximum torque

$T_a = 0.163 \text{ [N-m]} < 1.91 \text{ [N-m]}$ [Maximum torque of Hiwin 200W Servo motor]

■ Verification of effective torque

$$T_{rms} = \sqrt{\frac{T_a^2 \times t_a + T_f^2 \times t_b + T_d^2 \times t_d}{t_c}}$$

$$= \sqrt{\frac{0.163^2 \times 0.1 + 0.017^2 \times 0.8 + 0.129^2 \times 0.1}{2}}$$

$$= 0.048 \text{ [N-m]}$$

$0.048 \text{ [N-m]} < 0.64 \text{ [N-m]}$ [Rated torque of Hiwin 200W Servo motor]

■ Evaluation

Judging from the inertia ratio calculated above, selection of 200W motor is preferable, although the torque margin is significantly large.

11. Motor / Drive Requirements List

Customer :		Date :
Email :		Contact Person :
Drive series	<input type="checkbox"/> D2T <input type="checkbox"/> D2	Title :
AC Motor Series*	Low inertia : <input type="checkbox"/> 50W <input type="checkbox"/> 100W <input type="checkbox"/> 200W <input type="checkbox"/> 400W Middle inertia : <input type="checkbox"/> 50W <input type="checkbox"/> 100W <input type="checkbox"/> 400W <input type="checkbox"/> 750W <input type="checkbox"/> 1000W <input type="checkbox"/> 2000W Format : <input type="checkbox"/> 13bit Incremental <input type="checkbox"/> 17bit incremental <input type="checkbox"/> 17bit absolute	Note :
Key*	<input type="checkbox"/> No <input type="checkbox"/> Yes	
Brake*	<input type="checkbox"/> No <input type="checkbox"/> Yes	
Seal*	<input type="checkbox"/> No <input type="checkbox"/> Yes	
AC input voltage(V)	<input type="checkbox"/> Single phase 220V <input type="checkbox"/> Three phase 220V	
Servo motor connecting wires*	Motor power (flexure resistance) Cable Length : <input type="checkbox"/> 3M <input type="checkbox"/> 5M <input type="checkbox"/> 7M <input type="checkbox"/> 10M Encoder (flexure resistance) Cable Length : <input type="checkbox"/> 3M <input type="checkbox"/> 5M <input type="checkbox"/> 7M <input type="checkbox"/> 10M	
Related accessory requirements*	<input type="checkbox"/> Pulse Wire <input type="checkbox"/> USB cable <input type="checkbox"/> Single-phase filter <input type="checkbox"/> Three-phase filter	
Control mode*	<input type="checkbox"/> Position control <input type="checkbox"/> Velocity control <input type="checkbox"/> Torque control <input type="checkbox"/> EtherCAT(CoE) <input type="checkbox"/> Others	
Match method	<input type="checkbox"/> Slide/model no: <input type="checkbox"/> Reducer/reduction ratio: <input type="checkbox"/> Timing belt <input type="checkbox"/> Gear rack <input type="checkbox"/> Ball screw/guiding distance: screw outer diameter:	
Host	<input type="checkbox"/> PLC/manufacture: model: <input type="checkbox"/> Axis card/manufacture: model:	
Special Need		
Installation	<input type="checkbox"/> Horizontal <input type="checkbox"/> Vertical	
Speed requirement		
Acceleration requirement		
Weight requirement		

The information below is to be filled out by HIWIN or authorized agents.

Recommended specifications :

Fields with * must be filled

Salesperson :

12. Safety Precautions

Thank you for purchasing HIWIN's AC servo motor. Installation and operation of the motor must be in accordance with the HIWIN manual. Before using the servo motor, please read these safety instructions and precautions carefully.

■ Unpacking instructions

1. Before using the servo motor, please read these safety instructions and precautions carefully. HIWIN is not responsible for any damage, accident, or injury caused by incorrect handling.
2. Examine the appearance of the motor for any unusual marks or damage from shipment.
3. Inspect the wires for damage.
4. Do not disassemble the motor. Since the product design has been based on structure calculations, computer simulations, and prototype testing, do not disassemble the product without the permission of HIWIN engineers.
5. Supervise children when handling this product.
6. People with psychosomatic illness or insufficient experience should not handle this product, unless under the direct supervision of managers or product narrators.

* If any items are damaged or incorrect, please contact your distributor or HIWIN sales representative.

■ Safety instructions

1. The product can only be repaired by HIWIN engineers. Please send the product back to us if there is any unusual phenomenon.
2. Do not hold the motor by its wire harness or shaft.
3. Do not hit the motor or shaft. Shock can damage the encoder inside the motor.
4. Do not apply loads to the motor shaft that are in excess of the specified value.
5. Protect the motor and encoder from high electrical noise, vibration, and unusual temperatures.
6. Do not change the motor parts or disassemble the screws. HIWIN will not be responsible for any damages, injuries, or accidents that may occur.

■ Wiring instructions

1. Ensure the specified power input value before using the product, and verify that the proper power supply is being used.
2. Before operation, please ensure that the motor, brake, and encoder are connected correctly. Incorrect wiring may cause abnormal motor operation or even cause permanent damage to the motor.
3. To avoid voltage coupling and electrical noise on the encoder, ensure adequate separation of the motor power wires and the encoder wires.
4. Ensure that the motor ground wire is connected to the ground terminal on the servo drive.
5. Do not perform a dielectric voltage-withstand test on any encoder terminal. The test may cause damage to the encoder.

■ Operation instructions

1. Higher than maximum specified current may cause demagnetization of magnetic components inside the motor.
2. The AC servo motor is designed to operate through a dedicated servo drive. Do not connect to a commercial power source (100/200V AC, 50/60 HZ). The motor will not operate correctly and may cause permanent damage.
3. The motor must be operated within its specified range.

4. Attention should be given to ensure adequate cooling and ventilation of the motor during operation.
5. For long term use, the motor shaft should be resupplied with proper and sufficient oil during the period of operation.
6. If any abnormal odor, noise, smoke, temperature rises or vibration is detected, stop the motor immediately. Remove power from the servo drive and isolated the motor.

■ Motor International Standard

		Drive	Motor
CE Directives 	EMC Directives	EMC: EN61800-3 EN55011 EN61000-6-2 EN61000-6-4 EN61000-2-4 IEC60146-1-1 IEC61000-2-1	EN55011 EN61000-6-2 EN61000-6-4
	Low-Voltage Directives	LVDS: EN61800-5-1	EN60034-1 EN60034-5
UL Directives		UL: E348161 (D2T 100W/400W/1000W)	UL1004-1 UL1004-6

■ Maintenance and Storage instructions

1. Do not store the product in an inflammable environment or with chemical agents.
2. Store the product in a place without humidity, dust, harmful gases, or liquids.
3. The motor shaft opening is neither waterproof nor oil-proof. Do not install the motor in an environment where there is harmful gas, liquid, excessive moisture, or water vapor.
4. Do not store the servo motor where it will be subjected to vibration or shock in excess of the specified limit.
5. The storage and transportation temperature of this product: $-20^{\circ}\text{C}\sim+65^{\circ}\text{C}$
6. Clean : Wipe with Alcohol (70%)
7. Before shipping, the motor shaft is coated with antirust oil to protect the motor shaft against rust formation. However, the material of the motor shaft is not entirely rust-proof. When the motor storage time has exceeded six months, please inspect and examine the motor shaft and resupply with proper and sufficient antirust oil at least once every three months thereafter.
8. Product disposal : Follow the local laws and regulations for recycling.

A one year guarantee is provided from the date of delivery. For product damage caused by improper operation (Please refer to the notes and instructions in this operation manual). HIWIN will not be held responsible for replacing or maintaining the product as a result of any natural disasters that may occur during this period.

 Warning : For the proper use of the HIWIN AC servo motor read these safety precautions carefully before installation, operation, and maintenance.

 Warning : Do not touch when motor operating to avoid being scalded.

- Please read "warning signs".
- Turn power off before clean product.
- Read manual before use.
- If the product is used under overload condition shell temperature rises.
- Without manufacturer's permission, please do not arbitrarily modify the device.
- It is difficult to ensure electromagnetic compatibility (EMC) problems do not occur in some environments.
- Removal of damaged power cable fasteners, with care and with attention for power cable fasteners.
- Avoid impact on of shaft end and encoder.
- Products cannot be used in environment with flammable materials.

MEMO

A series of horizontal dotted lines for writing.

AC Servo Motor & D2 Drive Technical Information

Publication Date : June 2008, first edition

Print Date : April 2017, 6th edition

-
1. HIWIN is the registered trademark of HIWIN Mikrosystem Corp.. For your protection; To avoid counterfeit products, be certain you are buying genuine HIWIN products before purchase.
 2. Actual products may be different from the specifications and photos in this catalog, The differences in appearances or specifications may be caused by, among other things, product improvements.
 3. HIWIN will not sell or export those techniques and products restricted under the "Foreign Trade Act" and relevant regulations. Any export of restricted products should be approved by competent authorities in accordance with relevant laws, and shall not be used to manufacture or develop nuclear, biochemical, missile and other military weapons.

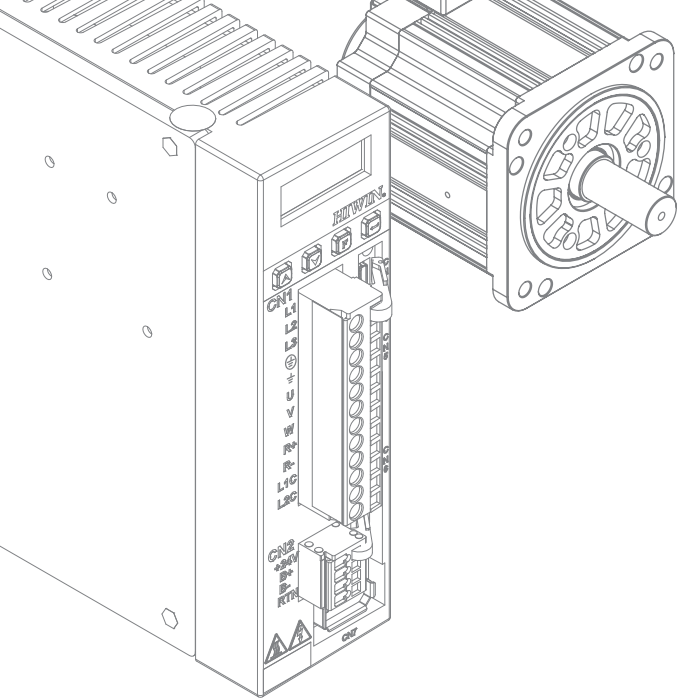

HIWIN®

Motion Control and System Technology

HIWIN MIKROSYSTEM CORP.

No.6, Jingke Central Rd.,
Taichung Precision Machinery Park,
Taichung 40852, Taiwan
Tel: +886-4-23550110
Fax: +886-4-23550123
www.hiwinmikro.tw
business@hiwinmikro.tw

Subsidiaries & R&D Centers

HIWIN GmbH
OFFENBURG, GERMANY
www.hiwin.de
www.hiwin.eu
info@hiwin.de

HIWIN JAPAN
KOBE · TOKYO · NAGOYA · NAGANO ·
TOHOKU · HOKURIKU · HIROSHIMA ·
KUMAMOTO · FUKUOKA, JAPAN
www.hiwin.co.jp
info@hiwin.co.jp

HIWIN USA
CHICAGO · SILICON VALLEY, U.S.A.
www.hiwin.com
info@hiwin.com

HIWIN Srl
BRUGHERIO, ITALY
www.hiwin.it
info@hiwin.it

HIWIN Schweiz GmbH
JONA, SWITZERLAND
www.hiwin.ch
info@hiwin.ch

HIWIN s.r.o.
BRNO, CZECH REPUBLIC
www.hiwin.cz
info@hiwin.cz

HIWIN SINGAPORE
SINGAPORE
www.hiwin.sg
info@hiwin.sg

HIWIN KOREA
SUWON, KOREA
www.hiwin.kr
info@hiwin.kr

HIWIN CHINA
SUZHOU, CHINA
www.hiwin.cn
info@hiwin.cn

Mega-Fabs Motion System, Ltd.
HAIFA, ISRAEL
www.mega-fabs.com
info@mega-fabs.com